

REAR VIEW

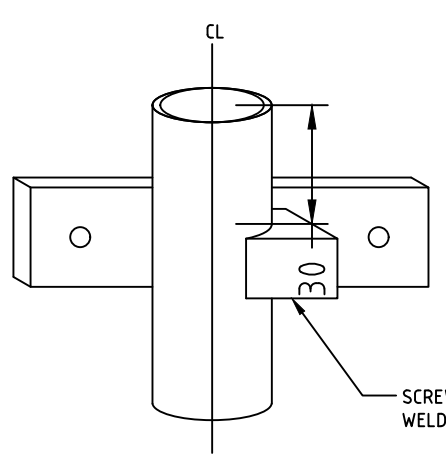

FRONT VIEW

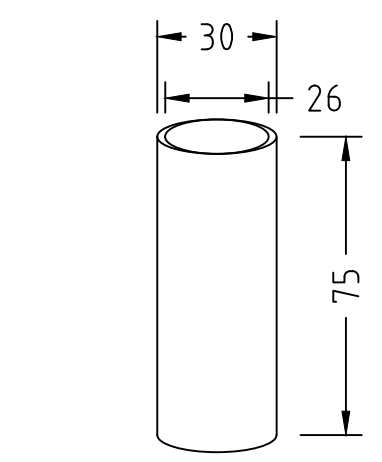
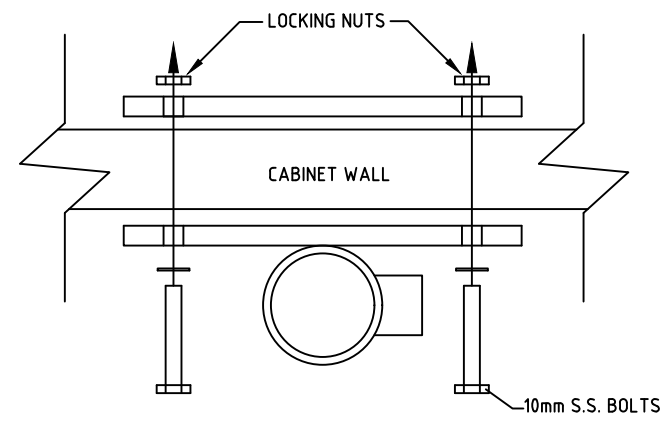

PLAN VIEW

NOTE 1:

TOP BRACKET

NOTE: ALL DIMENSIONS IN MILLIMETERS

NOTE 1: CONTACT TSC MECH / ELEC FOR SUPPLY OF POLE AND BRACKETS

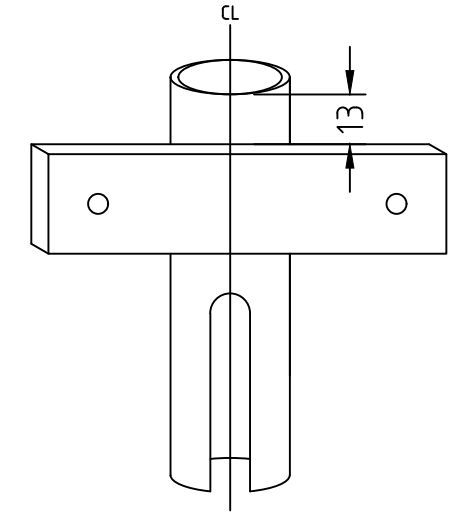
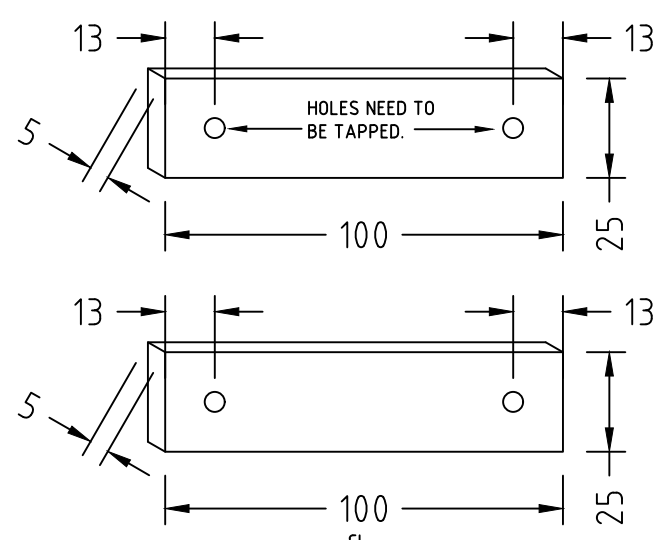
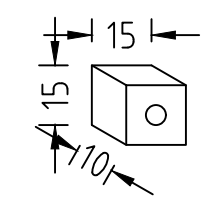

REAR VIEW

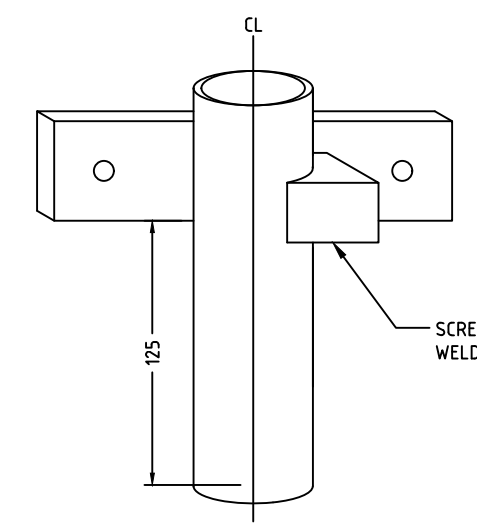
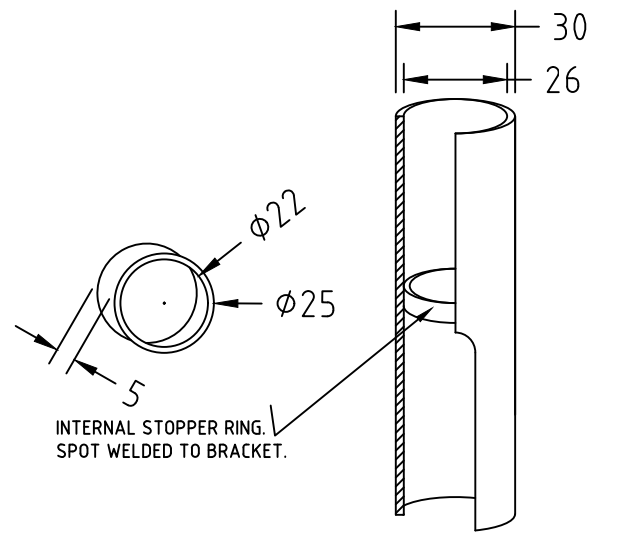

FRONT VIEW

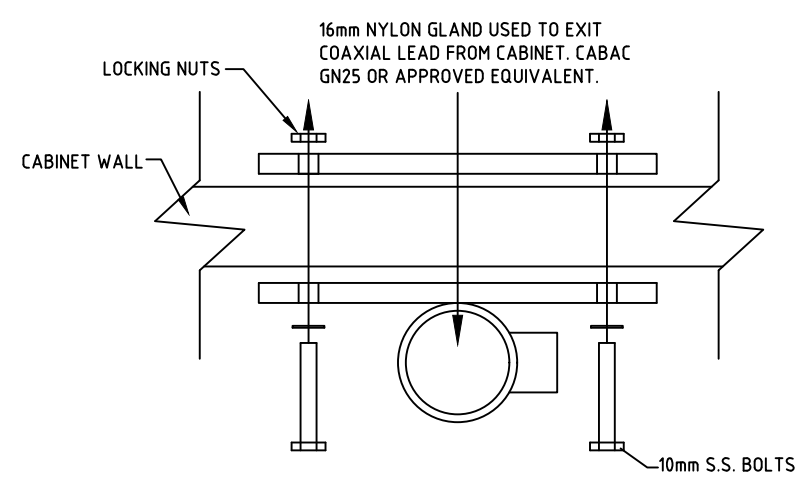

PLAN VIEW

NOTE 1:

BOTTOM BRACKET

ISSUE	AMENDMENT DETAILS	Drawn	Checked	Approved	Date
00	ORIGINAL ISSUE			D.F	3.8.12
01	AMENDED ISSUE RELEASED FOR PUBLICATION	E.K	P.B	D.F	13.08.13
02	SHEET NAME UPDATE	P.B	D.R	J.G	20.08.20

**ELECTRICAL UNIT**  
 COUNCIL OFFICES  
 ALTONA ROAD,  
 CUDGEN NSW 2487.  
 PHONE 02 66740342  
 FAX 02 66741069  
 WEBSITE www.tweed.nsw.gov.au

DESIGNED:	<i>[Signature]</i>
DRAWN:	<i>[Signature]</i>
APPROVED:	<i>[Signature]</i>
SCALE	NTS
ACAD FILE No.:	

PROJECT:	SEWAGE PUMP STATIONS ELECTRICAL STANDARD DRAWINGS
PLAN TITLE:	SWITCHBOARD CABINET DETAILS SHEET 3 OF 3

DRAWING NUMBER: <b>SD-820/16</b>	
SHEET	16 OF 19
REV	02
DATE	20/08/2020