



TWEED
SHIRE COUNCIL

Policy

Rainwater Tanks in ~~Service~~d Areas with
Reticulated Water

Version 3.01

Adopted by Council at its meeting on ~~Thursday 17 September 2015~~xxx

Minute No: ~~607~~xxx

DRAFT

Division:
Section:
File Reference:
Historical Reference:

Community and Natural Resources
Natural Resource Management
Council Policies/Protocols/Procedures
1.0 Adopted 2 November 2005
1.1 Adopted 13 November 2007
2.1 Adopted 20 September 2011
Reviewed 20 June 2013
3.0 Adopted 17 September 2017

THIS PAGE IS BLANK

DRAFT

Rainwater Tanks in Serviced Areas

Policy Objective

- To facilitate the installation and use of rainwater tanks in Tweed Shire to:
 - Supplement the Tweed Shire bulk water supply.
 - Reduce the consumption of treated potable water for non-potable uses.
 - Reduce the intensity and frequency of stormwater runoff from serviced areas.
- To outline the necessary requirements to protect the public water supply from contamination and to ensure public health is not compromised.

Definitions

Direct Inter-Connection: Where the town main water supply is connected to the **outlet** of the rainwater tank supply via a three-way valve. Direct connection also occurs where a pipe containing water from Council's reticulated supply is directly connected into a tank or pipe containing water from a rainwater tank, or, where the outlet of a pipe containing Council's reticulated supply is submerged beneath the surface of water from a rainwater tank.

Indirect Inter-Connection: Where the **outlet** of a pipe containing water from the town main water supply is separated from the water in the rainwater tank by a visible air gap.

Below ground rainwater tank: A tank collecting roof water only which is either fully or mostly underneath the ground and/or where the view of and access to any one of the air gap, inlet pipe or overflow pipe is obscured by the ground or something similar e.g. rockery or garden bed. There should be no possibility that surface run-off e.g. on a sloping site will drain to a rainwater tank.

Above ground rainwater tank: A tank collecting roof water only which is either fully above ground or at least half the tank is above ground and the view of and access to the inlet pipe, air gap and overflow pipe are unobstructed.

Visible air gap: The unobstructed vertical distance (50mm) through the free atmosphere between the lowest opening of a water service pipe or fixed outlet supplying water to a fixture or receptacle and the tank opening level of such fixture or receptacle. Refer to *Appendix 4 – Typical Rainwater Tank Cross Section*.

Non-testable Dual Check Valve (DCV): A device to prevent backflow caused by backpressure, which incorporates two independently operating force loaded non-return valves.

Testable Double Check Valve (TDCV): A device to prevent backflow caused by back pressure, and which has two independently operating force loaded non-return valves and incorporates specific test points for in-service testing.

Maximise: To maximise something is to make it as large, long or high as possible.

Trickle top-up: Trickle top-up is the slow filling of the tank from the drinking water (reticulated) supply. It is designed to minimise effects on the reticulated system and allow for a reasonable re-supply into the tank over a period of several hours.

Policy Background

This Policy applies to rainwater tanks installed on properties in Tweed Shire that are connected to the public water supply.

Policy

Why We Need Rainwater Tanks

Supplementing the Bulk Water Supply

Whilst all mains water is treated to drinking water standards, less than 5% of this water is consumed for drinking. Toilet flushing, laundry and outdoor uses represent a significant portion of domestic water consumption but these do not require water to be treated to such a high standard. Similarly, water used by business for activities such as irrigation, vehicle washing and cooling towers does not require treatment to such a high standard. Such uses can be satisfactorily supplied from rainwater collected from roofs and stored in tanks.

It is often mistakenly assumed that using rainwater solely for outdoor uses such as watering the garden will produce substantial mains water savings. However mismatches between seasonal rainfall and outdoor water use patterns can result in poor utilisation of rainwater, resulting in long periods during which the tanks are either empty or full. To effectively supplement the bulk water supply, rainwater tanks need to be connected to water uses in the home (e.g. toilet, washing machine) so that water from the tank is used at a relatively constant rate and there is available space in the tank to capture water from the next rain event.

Utilising rainwater for various uses (e.g. toilet flushing, garden watering and clothes washing) can result in optimum mains water savings and large reductions in stormwater discharges, especially where the area of the roof catchment that supplies the tank(s) is maximised (e.g. between 80% and 100%)

Reducing the Consumption of Treated Potable Water for Non-potable Uses

The implementation of Council's Demand Management Strategy has set a residential water consumption target of 170 litres per person per day by the end of 2016. One of the ways to achieve this target is to reduce the consumption of treated potable water from the public water supply that is used for non-potable uses. Council is therefore encouraging the installation of rainwater tanks to provide non-potable water for outdoor uses, flushing toilets and washing machines. Council is also encouraging commercial and industrial water customers to look at ways to replace potable water consumption with rainwater.

For this approach to be as successful as possible customers are being encouraged to install the largest tank that they can, given factors such as initial cost, space and ongoing operating and maintenance costs.

A minimum tank size of 5000 litres with a minimum roof catchment area of 160 square metres is recommended for single dwellings. For duplexes, triplexes, multi-dwellings and other buildings, it is recommended that the rainwater tank volume be maximised with 80% to 90% of the roof area connected.

Reducing the Intensity and Frequency of Stormwater Runoff from Urban Areas

Urban areas increase the amount of impervious surfaces (e.g. driveways, roads, paths, roofs) in a catchment. This impairs the catchment's ability to absorb rainwater and results in larger volumes of runoff.

By retaining rainwater on-site, rainwater tanks reduce the volume of water discharged to creeks and streams in the catchment. This also reduces the velocity or energy of water entering creeks and streams, which in turn, reduces downstream scour, sedimentation and riparian vegetation removal.

By capturing and retaining rainwater, tanks lessen the amount, intensity and frequency of downstream stormwater runoff and thereby partially offset the adverse impacts of urbanisation.

Rainwater Uses

Rainwater can provide an alternative source of water for the following:

- Toilet flushing
- Domestic washing machines and commercial laundries
- irrigation and other outdoor water use
- Washing cars and commercial vehicles
- ornamental ponds and fountains
- Topping up swimming pools and spas
- Cooling towers
- Washing driveways and outdoor commercial areas

Where there is a reticulated drinking (potable) water supply available to the property, NSW Health does not recommend the use of rainwater for:

- Drinking
- Cooking or other kitchen purposes
- Personal washing, such as baths, showers, hand basins and bidets

Connection of the rainwater tank supply to the household hot water system is not recommended as hot water is generally used for potable uses within the home. Depending on the condition and the construction materials of the roof catchment and tank, connection to the hot water system may also increase the likelihood of scaling and fouling of the hot water heater.

Desirable Characteristics for Rainwater Tank Systems

The following characteristics are desirable to maximise the positive environmental impacts and water supply yield of rainwater tank systems:

- a) Maximise the volume of the tank/s. A minimum tank volume of 5000 litres is recommended for single dwellings.
- b) Maximise the area of the roof catchment that is spouted to the tank so that the maximum amount of water is captured. A minimum roof catchment area of 160 square metres is recommended for single dwellings.
- c) Maximise the continuous tank draw down (to make space available to capture water from the next rain event) by connecting toilet cistern(s), the cold water supply to the washing machine and the majority of external garden taps.
- d) Elevate the tank so that the base of the tank is a minimum of 1m above connected internal taps or cisterns so there is adequate operating pressure. This may avoid the need to install a pressure pump on the tank outlet, reducing energy use and the associated costs. If it is not feasible to elevate the tank or if there is insufficient pressure to operate all taps and cisterns, the tank will need to be fitted with a pressure pump.
- e) For commercial and industrial water tanks, maximise the volume of the tank/s and roof catchment area/s.

Water customers are encouraged to install the largest tank that they can, given factors such as initial cost, space and ongoing operating and maintenance costs.

It is sometimes difficult to collect rainwater from multiple roof areas (e.g. both sides of the roof catchment). Some options to address this include strapping downpipes to the house walls, using an underground (siphon) connection, installing more than one tank, siting the tank underground or installing a rainwater collection system that utilises the roof guttering as the water storage compartment.

Approval to Install a Rainwater Tank

The NSW Government's State Environmental Planning Policy (Exempt and Complying Development Codes) 2008 sets out conditions under which rainwater tanks may be installed without the approval of Council. Rainwater tanks with a capacity of 10,000 litres or less do not require local Council approval provided they meet all of the conditions outlined in the SEPP.

The SEPP conditions vary for above ground and below ground tanks and also vary depending on the zoning of the land where the tank/s is/are to be installed. Different conditions apply for land that is zoned rural or environmental, educational establishments and installations in acid sulphate soils. Council's Building and Environmental Health Unit (02 6670 2440) should be consulted to ascertain the SEPP and approval requirements if in doubt. Refer to Appendix 1 for a full list of the SEPP conditions for above ground and below ground tanks.

One of the important SEPP conditions is that: “If reticulated water is provided to the lot, the development must not be interconnected with any system supplying drinking water to the lot unless it complies with the relevant water authority’s requirements”. This refers to rainwater tanks that are topped up from the town water supply or either directly or indirectly cross-connected with the town water supply. In such cases, while the tank may still be deemed Exempt Development, Council approval of the connection is required.

Consequently, in Tweed Shire, Council approval to install a rainwater tank is required when:

- a) the tank volume is greater than 10,000 litres; or
- b) any of the other SEPP conditions are not met (see Appendix 1); or
- c) the tank is to be topped up from the reticulated water supply; or
- d) the tank is directly or indirectly cross-connected with the reticulated water supply; or
- e) the tank or part of the tank is to be located below ground

If Council approval is required, Council’s Building and Environmental Health Unit (02 6670 2440) should be consulted to ascertain the approval requirements for the specific rainwater tank system.

Generally, if the tank volume is 10,000 litres or less, all other SEPP conditions are met (see Appendix 1) and the tank is not going to be topped up, connected to the house plumbing or otherwise cross-connected with the reticulated water supply, no approval is required from Council.

If the tank volume is 10,000 litres or less, all other SEPP conditions are met (Appendix 1) but the tank is to be topped up, connected to the house plumbing or cross-connected with the reticulated water supply, Council approval is required. An *Application for Approval of Plumbing and Drainage Work on Private Land* is required (Appendix 2) and the work must be completed by a licensed plumber. The plumber is required to lodge an *Notice of Work for Plumbing and Drainage Work* (Appendix 3) before proceeding with the work.

Where the development is not Exempt as detailed above, the tank may still be eligible for approval as Complying Development under the SEPP or if this is not the case, a Development Application is required. Council’s Building and Environmental Health Unit (02 6670 2440) should be consulted to ascertain the specific approval requirements.

Development Approval

For tank installations that do not meet the SEPP conditions (see Appendix 1), Council may require the following information as part of a Development Application (DA):

- A site plan and associated documentation detailing:
 - position of the tank in relation to other structures and services (including easements);

- tank dimensions including height, diameter, and volume;
- area (m²) of the roof catchment area spouted to the tank(s);
- location and volume of the first flush diversion device (mandatory);
- plumbing configurations including design details for power failure protection;
- tank top-up technique;
- backflow prevention;
- location of the pump (where applicable);
- depth of the tank below ground and (where applicable) how the excavation for the tank will comply with Council's 'Acid Sulphate Soil Management Plan for Minor Works';
- relevant information on how rainwater pipes, taps and tanks will be clearly and permanently identified as 'RAINWATER';
- relevant structural details of the tank and its supports;
- how the installation will comply with the relevant Australian Codes and Standards.

Appendix 4 of this policy provides some drawings of plumbing configurations for typical rainwater tank systems.

General Requirements

This section provides a summary of Council's general requirements for rainwater tank installations.

For more detailed information about the design, installation, maintenance and use of rainwater tank systems, Council recommends reference to the *Rainwater Tank Design and Installation Handbook* published by Standards Australia and/or *Guidance on use of rainwater tanks* published by enHealth (see *References*).

Backflow Prevention

Backflow prevention (*refer to Table 1 below*) shall comply with the relevant sections of AS/NZS 3500.1:2003-2015 Plumbing and drainage – Part 1: Water services. Backflow prevention devices shall comply with AS/NZS 2845.1.

Backflow prevention at the property boundary is generally achieved via Council's water meter.

For reference, *Appendix 4* provides drawings of backflow prevention requirements for typical tank installations.

Table 1: Backflow Prevention Requirements for Rainwater Tank Systems

Tank Configuration	Hazard Rating	Backflow Prevention Device at Property Boundary Water Meter	Backflow Prevention Device at Connection Point of Rainwater Control Valve or Tank Top Up
above ground rainwater tank	Low	Non-testable Dual Check Valve (DCV) i.e. Council's water meter.	<i>Non-testable Dual Check Valve (DCV) Or Visible Air Gap (for rainwater tank top up only)</i>
below ground rainwater tank	Medium	Non-testable Dual Check Valve (DCV) i.e. Council's water meter.	<i>Testable Double Check Valve</i>

An air gap refers to a physical separation between the mains water and rainwater supplies within the tank. All air gaps must be visible and comply with the relevant sections of AS/NZS 3500.1:[2003-2015](#) or as otherwise approved by Council.

Contact the Building and Environmental Health Unit on (02) 66702440 for more information about specific backflow prevention requirements if necessary.

Tank Top-Up

Top-up is to be limited to a *trickle top-up* to ensure that the water pressure to other customers is not compromised. Trickle top-up is the slow filling of the tank from the drinking water supply. It is designed to minimise effects on the reticulated system and allow for a reasonable re-supply into the tank over a period of several hours.

- If the rainwater tank is to be topped up by the town water main it must comply with AS/NZS3500.1:[2003-2015](#) sections 8 and 14.3; and
- For single residential dwellings the minimum flow rate from the town water main top-up valve is 2 litres/minute and the maximum flow rate is 4 litres/minute; and
- For multi-dwellings and units the minimum flow rate from the town water main top-up valve is 2 litres/minute and the maximum flow rate is 4 litres/minute multiplied by the number of townhouses or units in the development; and
- Flow rate control valves are to comply with AS6400 Water efficient products – Rating and labelling and ATS 5200.037.1:2006 Technical specifications for plumbing and drainage products - Flow controllers. Flow control valves are to be installed integral with the inline stop tap immediately upstream of the ball float control device or solenoid device; and
- Town main top-up valves are to be installed in an accessible location (valves on top of the rainwater tank). No valves are to be installed in the rainwater tank; and
- Valves are to have a maximum flow tolerance of +/- 10% under various pressure fluctuations; and
- Flow control valves are to have a minimum warranty of 5 years; and
- The mains replenishing must not fill the tank above 15% level.

All relevant information to support any proposed tank top-up technique must be supplied to Council.

Council approval is required for any proposed tank top-up technique.

In-Ground Rainwater Tanks

The *State Environmental Planning Policy (Exempt and Complying Development Codes) 2008* sets out conditions under which below ground rainwater tanks may be installed without the approval of Council. Importantly, the SEPP only applies to tanks installed on land that is zoned rural or village. Check with Council's Building and Environmental Health Unit (02 6670 2440) to ascertain the SEPP and approval requirements if in doubt.

Below ground tanks that are cross-connected with the town water supply represent a medium risk to the town water supply. Special attention must be given to the backflow prevention requirements for such below ground rainwater tank systems. This is

because potentially contaminated water (e.g. stormwater, pesticide sprays) may enter the below ground tank and from there, the mains water supply.

All below ground rainwater tanks shall be sealed to prevent surface and/or groundwater from entering the tank.

The tank access lid is to be designed and installed to prevent child access.

Licensed Plumber

All plumbing work is to be carried out or supervised by a licensed plumber in compliance with this policy and AS/NZS 3500.1:~~2003~~2015 Plumbing and drainage – Part 1: Water services.

For any plumbing work the licensed plumber must submit a *Notice of Work for Plumbing and Drainage Work* (Appendix 3) from Council prior to commencing the work.

Tank Volume and Roof Catchment Area

Water customers are encouraged to install the largest tank that they can, given factors such as initial cost, space and ongoing operating and maintenance costs.

For single dwellings, it is recommended that all rainwater tanks have a minimum storage capacity of 5,000 litres. A minimum roof catchment area of 160 square metres is recommended.

For duplexes, triplexes, multi-dwellings and other buildings, the tank volume should be maximised with 80% to 90% of the roof area connected to the tank.

Maximising the area of roof catchment spouted to the tank will mean more rainwater is captured in the tank every time it rains. This means less topping up from the mains water supply.

Underground Structures and Water/Sewer/Stormwater Mains

Rainwater tanks are not permitted to be built over a Tweed Shire Council maintenance structure, water or sewer main, stormwater drainage line, stormwater flow path or within any Council easement, regardless of tank size.

Above ground tanks must be located a minimum of 1 metre horizontally from the centreline of any water or sewer main, or any stormwater drainage line or flow path. Below ground tanks must be located to ensure no influence on adjacent water, sewer or stormwater mains. Council should be consulted about the specific requirements for below ground tanks on a case by case basis.

More detailed information about building near water and sewer mains can be found in Council's Policy entitled "Sewers – Work in Proximity", adopted by Council in November 2007.

Tank Overflow

The overflow pipework from rainwater tanks must provide a continuous fall to the stormwater system and must not discharge to Council's sewerage system. There

should be no other connections to the overflow pipework such as surface water inlets. This is to prevent foreign matter entering the overflow pipework and flowing back into the rainwater tank. To achieve this, some below ground rainwater tanks may be required to be located partially out of the ground and landscaped accordingly.

Inspection and Maintenance Reports

Testable backflow prevention devices are to be tested annually by an accredited plumber and a copy of the inspection and maintenance report forwarded annually to Council's Building and Environmental Health Unit for entry into Council's register.

Backflow prevention devices on below ground tanks (i.e. testable double check valves) also require annual testing by an accredited plumber. A copy of the inspection and maintenance report must be forwarded annually to Council's Building and Environmental Health Unit for entry into Council's register (for more information phone 02 66702440).

Dual Check Valves

Non-testable Dual Check Valves installed on rainwater tank systems are required to be replaced every five years.

Dual Check Valves can only be installed on above ground rainwater tanks.

Rainwater Control Valves

Rainwater Control Valves such as Rainbank, Rainsaver and similar products may be used. Systems using rainwater control valves must be fitted with two dual check valves on the mains supply. One after the potable water meter and one before the connection to either the rainwater tank or internal plumbing that is also fed from the rainwater tank.

All rainwater control valves shall have the WaterMark compliance certification in accordance with ATS5200.466:2004 and/or ATS5200.462:2004.

Contact the Building and Environmental Health Unit on (02) 66702440 for more information if required.

First Flush Diverters

For a tank to satisfy the SEPP (Exempt and Complying Development Codes) 2008 requirements, the tank must "be fitted with a first-flush device that causes initial run-off rainwater to bypass the tank".

For all tanks, Council recommends that an appropriately sized first-flush diversion device be installed to reduce the likelihood of contaminants that have accumulated on the roof and in the gutters entering the tank.

The *Guidance on use of rainwater tanks* prepared by enHealth (page 22) suggests that for an average roof catchment the first **20-25 litres** could be diverted or discarded.

First flush devices need to be empty when a rain shower begins. Although many commercially available first flush diverters are designed to empty themselves after a rain event, they need to be inspected regularly and when necessary, emptied manually.

Adequate provision should also be made for the drainage/overflow from such a device so that the resulting discharge does not create a nuisance.

Refer to *Appendix 4* for an example of a typical first-flush device installation.

Pipes and Labelling

Pipe materials for rainwater supply plumbing need to be approved products and be clearly and permanently identified as 'RAINWATER'. This can be done for below ground pipe by using identification tape (made in accordance with AS2648) or for above ground pipes by using adhesive pipe markers (made in accordance with AS1345).

Every rainwater tank outlet shall be labelled 'RAINWATER' on a metallic sign in accordance with AS1319.

Bushfire Prone Areas

Rainwater tanks and associated pipework installed in bushfire prone areas must be constructed of non-combustible material such as metal or concrete.

Energy Use

To minimise energy use and its associated costs, it is desirable to elevate the tank to provide adequate operating pressure, avoiding the need to install a pump on the tank outlet. As a guide, the base of the tank will need to be a minimum of 1m above connected internal taps or cisterns to provide the necessary pressure. Ensure that any structure or stand erected to support or raise the tank complies with Council's building requirements.

If it is not feasible to elevate the tank or if there is insufficient pressure to operate all taps and cisterns, the tank will need to be fitted with a pressure pump.

Energy use by pumps can be significant and wherever possible, gravity systems are preferable. If a pump is to be installed, ensure that it is selected for the pressure head, flow rate and operating frequency required. An oversized pump will use more energy than required.

Tank Pumps

The *SEPP (Exempt and Complying Development Codes)* requires that pumps attached to tank systems must be housed in a soundproof enclosure.

All rainwater tank pumps shall be installed in a way that ensures that the resulting noise does not create a nuisance to occupants of the home or any neighbouring properties.

If a pump is installed external to the tank an acoustic enclosure may be necessary such as a box/cover with an absorbent lining.

To reduce the potential for noise concerns from rainwater tank pumps in areas of small block sizes and/or where houses are built close to boundaries, the following specifications are suggested:

- installation of submersible rainwater pressure pumps; and/or
- installation of a solid fence or lapped fence palings; and/or
- locating the pump as far away as possible from neighbours and away from sensitive areas such as bedroom windows; and/or
- locating the pump away from noise-reflective surface (e.g. alcoves, walls).

Power Failure Protection

Where an electric pump is used to transport rainwater from the tank to the house, the plumbing configuration must be designed to allow for essential fixtures (e.g. toilet) to operate in the event of a pump or power failure.

Tank Maintenance and Water Quality

Council recommends the proper use and maintenance of rainwater tanks in accordance with the publication “*Guidance on use of rainwater tanks*” prepared by enHealth. A copy of this document is available online from the Department of Health and Ageing’s website at: <http://www.health.gov.au/internet/main/publishing.nsf/Content/ohp-enhealth-raitank-cnt.htm>

The NSW Department of Health (NSW Health) provides an additional Guideline and Brochure relating to “*Use of Rainwater Tanks Where a Public Water Supply is Available*”. This Guideline is available on the NSW Health website at: <http://www0.health.nsw.gov.au/publichealth/environment/water/rainwater.asp>

Of particular concern in urban areas of the Tweed Shire is the potential for tanks to encourage the breeding of mosquitoes and other insects. The enHealth guideline referenced above (page 22) provides detailed information about how to prevent mosquito breeding in and around tanks. As a last resort, it also describes how to treat an existing mosquito problem. As a minimum:

- ✓ unless in use, all access points excluding the inlet and any overflows, should be kept shut with close fitting lids that will prevent mosquito access; and
- ✓ inlets and overflows should be covered with closely fitting removable insect-proof screens; and
- ✓ rainwater should not be allowed to pool in containers or on surfaces below tank outlets or taps, as this can also provide a breeding site; and
- ✓ water ponding in gutters needs to be prevented as it can provide breeding sites for mosquitoes and could lead to eggs being washed into the tank.

In urban areas, NSW Health recommends that people use the public water supply for drinking and cooking because it is filtered, disinfected and generally fluoridated. The quality of Council’s town water supply is regularly monitored.

Lead Flashing and PVC Pipe Additives

Lead flashing is sometimes used on roofs where stepped flashing is required, for example where a roof is flashed at the junction of a masonry exterior wall. Lead flashing should not be used on roofs that catch potable water. Alternatives to lead flashing include malleable coated aluminium, malleable zinc and colorbond or zinc aluminium.

In the past, some PVC pipe contained lead stabilisers which were used to increase the durability of the pipe. Although most manufacturers have phased out the use of lead stabilisers, care should be taken when selecting pipe for potable water supply. PVC pipe containing lead stabilisers is not recommended for use in rainwater tank installations if the harvested water is likely to be used for potable uses.

New Development – BASIX Requirements

All new residential development must comply with the State Government's Building Sustainability Index (BASIX) requirements which often require the installation of a rainwater tank. The aim of BASIX is to reduce the water and energy use of new dwellings and set a minimum standard for the water and energy efficiency of new development.

In keeping with Council's adopted Demand Management Strategy, this Policy is complimentary to BASIX and aims to go a step further to reduce water demand in the Tweed Shire. While Council cannot override the BASIX requirements, for single dwellings this Policy recommends a minimum tank size of 5000 litres, capturing rainwater from a roof catchment area of 160 square metres or more. For multi-dwellings, the maximum possible tank size and 80% to 90% of the roof catchment area are recommended.

New development and subdivisions must also comply with any additional requirements of Council's Development Control Plans and Development Codes, specific to those developments and precincts.

Note that any adjustments to a rainwater tank system installed to comply with BASIX need to be consistent with the BASIX Certificate pertaining to the property. In some cases adjustments of the rainwater tank system may necessitate changes to the BASIX Certificate.

New Subdivisions – Eligible Rainwater Tank Systems

This section applies to new subdivisions where eligible rainwater tank systems are required on future dwellings as a condition of the consent for the subdivision.

All new subdivisions are required to:

- Treat stormwater to remove pollutants.
- Retain and reuse stormwater so that subdivision stormwater flows mimic pre-development flows.

For large subdivisions (>50 lots or >5ha) constructed wetlands are required to remove sediments, pollutants and nutrients from the stormwater runoff. Table 7.11-WS of Council's *Development Design Specification D7 Stormwater Quality* provides the deemed to comply sizing of such constructed wetlands. The installation of eligible rainwater tank systems on residential lots allows for a reduction in the sizing of those wetlands as per Table 7.11-WS. This requirement will be enforced as a "restriction to

user” covenant on each land title deed in the subdivision if the stormwater system is approved on the basis of Table 7.11-WS.

As well as complying with the requirements of this Policy, eligible rainwater tank systems must also comply with the following additional requirements, as outlined in Table 7.11-WS:

- (a) a minimum sized tank of 5,000 litres, equipped with an automatic pressure pump and mandatory permanent connection to all toilets and laundry cold water; and
- (b) other connections for outdoor use are optional; and
- (c) mandatory connections are to ensure tanks are continually used and have space available for detention of stormwater runoff; and
- (d) the tank is to be replenished with mains water and ballcock control device when the tank falls below 15%; and
- (e) the mains replenishing must not fill the tank above 15% level; and
- (f) the mains inlet shall be provided with a regulation air gap to prevent cross connection; and
- (g) tank inlets are to be provided with screens and first flush bypass devices; and
- (h) compliance with minimum rainwater tank standards in BASIX will not qualify a tank as an eligible rainwater tank; and

Eligible rainwater tank systems will be inspected by Council on an annual basis or as required to ensure they remain compliant with this Policy.

Currency of this Policy

The information contained in this Policy is correct and up to date as at the adoption date. Since legislation, guidelines and standards change from time to time, readers of this Policy are advised to check the latest version of these requirements, in particular:

- Australian Standards
- Guidance on use of rainwater tanks, enHEALTH
- Rainwater Tank Design and Installation Handbook, Standards Australia
- State Environmental Planning Policy (Exempt and Complying Development Codes)

References

enHealth, Guidance on use of rainwater tanks, Commonwealth of Australia, 2010
(available on the NSW Health website at: <http://www.health.gov.au/internet/main/publishing.nsf/Content/health-publth-publicat-environ.htm>)

<http://www.health.gov.au/internet/main/publishing.nsf/Content/health-publth-publicat-environ.htm>

Standards Australia, Rainwater Tank Design and Installation Handbook, Second edition, 2008

State Environmental Planning Policy (Exempt and Complying Development Codes), 2008; Subdivision 32 Rainwater tanks (above ground); Subdivision 33 Rainwater tanks (below ground)

AS/NZS 3500.1:~~2003~~2015 Plumbing and drainage – Water Services

ATS 5200.466:2004 Technical specifications for plumbing and drainage products – Rainwater tank connection devices

ATS 5200.462:2004 Technical specifications for plumbing and drainage products – Rainwater tank connection valve

AS/NZS 2648.1:1995 Underground marking tape

AS 1345:1995 Identification of the contents of pipes, conduits and ducts

AS 1310:1994 Safety signs for the occupational environment

AS/NZS 6400:2005 Water efficient products – Rating and labelling

APPENDIX 1

(as at 14 May 2015)

State Environmental Planning Policy (Exempt and Complying Development Codes) 2008

Subdivision 32 Rainwater tanks (above ground)

2.63 Specified development

The construction or installation of a rainwater tank above ground is development specified for this code if it is not constructed or installed on land in a foreshore area or in an environmentally sensitive area.

2.64 Development standards

- (1) The standards specified for that development are that the development must:
 - (a) if it is on land other than land in Zone RU1, RU2, RU3, RU4, RU6, R5, E2, E3 or E4:
 - (i) for an educational establishment—not have a capacity of more than 25,000 L, and
 - (ii) in any other case—not have a capacity more than 10,000 L, and
 - (iii) be located at least 450mm from each lot boundary, if the tank has a height of more than 1.8m above ground level (existing), and
 - (b) if it is on land in Zone RU1, RU2, RU3, RU4, RU6, R5, E2, E3 or E4—be located at least 10m from each lot boundary, and
 - (c) be located behind the building line of any road frontage, and
 - (d) not rest on the footings of an existing building for support, and
 - (e) not require cut and fill of more than 1m below or above ground level (existing), and
 - (f) be fitted with a screened rain head designed to ensure self-cleaning and prevent leaf litter entering into the water tank, and
 - (g) be fitted with a first-flush device incorporating an automatic resetting valve that causes initial run-off rainwater to bypass the tank, and
 - (h) be constructed or installed with inlets and outlets designed to prevent mosquitoes breeding in it, and
 - (i) have its overflow connected to an existing stormwater drainage system that does not discharge to an adjoining property, or cause a nuisance to adjoining owners, and
 - (j) have a sign affixed to it with a statement to the effect that the water in the tank is rainwater, and
 - (k) if it is constructed or installed on or in a heritage item or a draft heritage item—be located in the rear yard.
- (2) Pumps attached to the development must be housed in an enclosure that is soundproofed.
- (3) If reticulated water is provided to the lot, the development must not be interconnected with any system supplying drinking water to the lot unless it complies with the relevant water authority's requirements.

(4) In this clause:

educational establishment means a building or place used for education (including teaching) and includes a pre-school, a school, a tertiary institution that provides formal education (such as a university or TAFE establishment) and an art gallery or museum that is not used to sell the items displayed in it (whether or not the building or place is also used for accommodation for staff or students).

Subdivision 33 Rainwater tanks (below ground)

2.65 Specified development

The construction or installation of a rainwater tank below ground is development specified for this code if:

- (a) it is constructed or installed on land in Zone RU1, RU2, RU3, RU4, RU6 or R5, and
- (b) it is not constructed or installed on land that is identified on an Acid Sulfate Map as being Class 1–5, and
- (c) it is not constructed or installed on land that is identified as an environmentally sensitive area.

2.66 Development standards

- (1) The standards specified for that development are that the development must:
 - (a) be fitted with a first-flush device that causes initial run-off rainwater to bypass the tank, and
 - (b) have a sign affixed to it stating the water in it is rainwater, and
 - (c) be constructed or installed to prevent mosquitoes breeding in it, and
 - (d) have its overflow connected to an existing stormwater drainage system that does not discharge to an adjoining property, or cause a nuisance to adjoining owners, and
 - (e) if it is constructed or installed on or in a heritage item or a draft heritage item—be located in the rear yard.
- (2) Pumps attached to the development must be housed in an enclosure that is soundproofed.
- (3) If reticulated water is provided to the lot, the development must not be interconnected with any system supplying drinking water to the lot unless it complies with the relevant water authority's requirements.

APPENDIX 2

Application for Approval of Plumbing and Drainage Work on Private Land

Customer Service | 1300 292 872 | (02) 6670 2400
 PO Box 816 Murwillumbah NSW 2484
 Fax (02) 6670 2429 | ABN 90 178 732 496
 tsc@tweed.nsw.gov.au | www.tweed.nsw.gov.au

[Instructions](#) [Print](#) [Clear Form](#)



Application for Approval of Plumbing and Drainage Work on Private Land

including sewer connection, hydraulic works and the installation of an on-site sewage management system (OSSM or Pressure Sewer Pump) Local Government Act 1993

(OFFICE USE)

Application No	<input type="text"/>	File No	<input type="text"/>	Date Received	<input type="text"/>
DA No	<input type="text"/>	Land No	<input type="text"/>	Property No	<input type="text"/>

A1. Pre-requisite to Complying Development
 Is this a pre-requisite to complying development? Yes No

A2. Application Type (work relates to)

<input type="checkbox"/> New Building	<input type="checkbox"/> Additions to existing building
<input type="checkbox"/> Caravan/manufactured home in existing park	<input type="checkbox"/> Connection from septic to sewer
<input type="checkbox"/> Not Applicable	

A3. Application for

- Approval to Carry out Work where reticulated water & sewer is available including connection to sewer
- Approval to Install a Private Sewage Ejection Pump Station [SEPejtpump]
- Approval to Operate an On-Site Sewage Management System (register system) [SEPOperate]
- Transfer of Approval to Operate for new owners (register system) [SEPOperate]
- Approval to Install a new On-Site Sewage Management System and or associated works (See attached requirements) [SEPNewHlth]; [InspectSep]; [SEPOperate]
- Approval to Modify or alter an existing On-Site Sewage Management System and or associated works (See attached requirements) [SEPNewHlth]; [SEPOperate]
- Application to Amend "Approval to Install" consent [SEPAmend]
- Minor Plumbing Works (applies to On-Site Sewage Management Systems Only) [SEP Add]

A4. Applicant

Surname/s	<input type="text"/>	Given Name/s	<input type="text"/>
OR			
Company/ Organisation	<input type="text"/>	ABN	<input type="text"/>
Postal Address	<input type="text"/>		
Telephone	<input type="text"/>	Mobile	<input type="text"/>
Facsimile	<input type="text"/>	Email	<input type="text"/>

Application for Approval of Plumbing and Drainage Work on Private Land
including sewer connection, hydraulic works and the installation of an on-site sewage management system
(OSSM or Pressure Sewer Pump) Local Government Act 1993

A5. Land Description

Lot No	<input type="text"/>	Section	<input type="text"/>	DP/NPP/SP	<input type="text"/>
Unit/Street No	<input type="text"/>	Street	<input type="text"/>		
Suburb/Town	<input type="text"/>				

A6. Owner's Consent

As the owner/s of the subject land, I/we give consent to the lodgement of this application and to an authorised officer of Council to enter the premises for the purposes of inspecting work relevant to this application.

Name/s ALL owners (please print)	<input type="text"/>
Company (if applicable)	<input type="text"/>
Signature/s ALL owners	<input type="text"/>

A7. Applicants Declaration

I declare that all the information in this application is true and correct.

I understand that if the information is incomplete the application may be delayed or rejected.

Applicants Name (please print)	<input type="text"/>		
Applicants Signature	<input type="text"/>	Date	<input type="text"/>

Application for Approval of Plumbing and Drainage Work on Private Land

Including sewer connection, hydraulic works and the installation of an on-site sewage management system (OSSM or Pressure Sewer Pump) Local Government Act 1993

NOTES

- Only plumbers and/or drainers licensed in NSW are permitted to carry out work and a plumber's Start Work Permit must also be obtained from Council prior to the commencement of any plumbing or drainage work. The owners are requested to insist upon the production of the Council final inspection report from the licensed plumber/drainers before making final payment to such licensed plumber/drainers.
- Applicants will be advised by Council in writing of the determination of their application. No work or activity is permitted to be undertaken until Council "Approval" is issued and a Plumbing & Drainage Permit processed.
- Applicants undertake to carry out any activity in compliance with the approval and any conditions of approval.

Attachments

Applications involving larger developments requiring hydraulic design eg multi residential, commercial, fire service upgrades, etc require three (3) copies of hydraulic drawings signed by a suitably qualified person. Applications involving on-site sewage management systems shall be accompanied by three (3) copies of an on-site sewage management design report signed by a suitably qualified person that includes:

Plan: A site plan drawn to scale, showing north point and the location of:

- The sewage management facility proposed to be installed or constructed on the premises; and
- Any related effluent application areas and reserve areas; and
- Any buildings or facilities (including swimming pools) or any environmentally sensitive areas (including permanent waterways) located within 100 metres of the sewage management facility or effluent application area

Specifications: The application must be accompanied by full specifications of the sewage management facility proposed to be installed or constructed on the premises concerned

Site assessment: The application must be accompanied by details of the topography soil composition and vegetation of any effluent application areas related to the sewage management facility together with an assessment of the site in the light of those details

Statement: A statement of:

- The number of persons residing, or probable number of persons to reside, on the premises; and
- Such other factors as are relevant to the capacity of the proposed sewage management facility

Operation and Maintenance: Details of:

- The operation and maintenance requirements of the proposed sewage management facility; and
- The proposed operation, maintenance and servicing arrangements intended to meet those requirements;
- The action to be taken in the event of a breakdown in, or other interference with, its operation

All fees current for 2012/2013 Financial Year		
SEWER APPLICATION FEES: (See Separate inspection fees below to be submitted with application fees)		
New Buildings and to Connect from Septic to Sewer	\$245.00	[SewerNew]
Additions to Existing Buildings including Caravan in existing park	\$122.50	[SewerAdd] [SewHealth]
SEWER INSPECTION FEES: (Minimum number of inspections required)		
	\$127.00	[InspectSew]
Note: No inspection fees apply for Uki, Dobbys Crescent, Burringbar, Mooball and The Parapet when connecting from Septic to Sewer Caravan in existing park – 1 inspection applies		
Single development application lodged with Council:		
Dwellings (3 inspections)	\$381.00	
Dual Occupancy - attached (3 inspections)	\$381.00	
Dual Occupancy - detached (4 inspections)	\$508.00	
All other buildings - by quotation		
Combined Development Application & Construction Certificate lodged with Council		
Dwellings (2 inspection)	\$254.00	
Dual Occupancy - attached (2 inspections)	\$254.00	
Dual Occupancy - detached (3 inspections)	\$381.00	
All other buildings - by quotation		
SEPTIC FEES: INCLUDES inspection fees		
Approval to Install a Private Sewage Ejection Pump Station	\$263.00	[SEPe] [pump]
Approval to Operate	\$68.00	(up to 4 systems) [SEPOperate]
Transfer of Approval to Operate	\$68.00	[SEPOperate]
Approval to Install	\$644.00	[SEPNewHlth] [InspectSep] [SEPOperate]
Approval to Modify or alter an existing On-Site Sewage Management System	\$390.00	[SEPNewHlth] [SEPOperate]
Application to Amend	\$77.00	[SEPAmend]
Minor Plumbing Works	\$226.00	[SEP Add]

[THIS NOTES PAGE IS NOT REQUIRED TO BE SUBMITTED WITH YOUR APPLICATION]

APPENDIX 3

Application for Permit to do Plumbing/Drainage Work



Regulator's Copy

NOTICE OF WORK
for Plumbing and Drainage Work
Please supply requested information correct and neatly

PROPERTY & OWNER DETAILS			
House No.	Street	Suburb	Postcode
<input type="text"/>	<input type="text"/>	<input type="text"/>	<input type="text"/>
Lot No.	DP No.	PDP or SP	Nearest Cross Street
<input type="text"/>	<input type="text"/>	<input type="text"/>	<input type="text"/>
Owner's Name	Full Address		
<input type="text"/>	<input type="text"/>		
LICENSEE'S DETAILS			
Full Name	Address for Notices		
<input type="text"/>	<input type="text"/>		
Phone No.	Qualified Supervisor No.	Expiry Date	
<input type="text"/>	<input type="text"/>	<input type="text"/>	
	Licence No.	Expiry Date	
	<input type="text"/>	<input type="text"/>	
WORK OF WATER SUPPLY			
Give full Description of Work carried out			
<input type="checkbox"/> Install Water Supply			
<input type="checkbox"/> Install Irrigation system			
<input type="checkbox"/> On-site Alternative Water Services			
<input type="checkbox"/> Install/Commission/Maintenance of Thermostatic Mixing Valve			
<input type="checkbox"/> Connection to water supply			
<input type="checkbox"/> Install, alter, disconnect or remove a backflow prevention device			
<input type="checkbox"/> Other			
<input type="text"/>			
<input type="text"/>			
<input type="text"/>			
PLUMBING WORK TO COMPLY WITH <input type="checkbox"/> AS/NZS3500 <input type="checkbox"/> ALTERNATIVE SOLUTION <input type="checkbox"/> COMBINED			
WORK OF SANITARY PLUMBING/DRAINAGE AND SUPPLY DRAINAGE PLAN			
Give full description of work carried out			
<input type="checkbox"/> Carry out work of sanitary plumbing/drainage			
<input type="checkbox"/> Connection to Sewer			
<input type="checkbox"/> Sewer Disconnection			
<input type="checkbox"/> Carry out Trade Waste Drainage			
<input type="checkbox"/> Other			
<input type="text"/>			
<input type="text"/>			
<input type="text"/>			
DRAINAGE WORK TO COMPLY WITH <input type="checkbox"/> AS/NZS3500 <input type="checkbox"/> ALTERNATIVE SOLUTION <input type="checkbox"/> COMBINED			
SEWERAGE/WATER SERVICE INSPECTION FEE			
Date Fee Paid	Date of Commencement of Work	Estimated Date of Completion	
<input type="text"/>	<input type="text"/>	<input type="text"/>	
Amount	Reference No:	Contractors Signature	
\$ <input type="text"/>	<input type="text"/>	<input type="text"/>	

1. This is your notification that you, as the Responsible Person, intend to carry out the work described on this 'NOTICE OF WORK', in accordance with provisions of the Regulators Act, Regulations, Codes and Standards.
2. This NOTICE TO WORK must be produced on the request of any person duly authorised by the REGULATOR.
3. The corresponding numbered CERTIFICATE OF COMPLIANCE must be submitted by you to the Local Regulator on the completion of a FINAL INSPECTION on the above work.

Owner's Copy

**CERTIFICATE OF COMPLIANCE
for Plumbing and Drainage Work**
Please supply requested information correct and neatly

PROPERTY & OWNER DETAILS			
House No.	Street	Suburb	Postcode
<input type="text"/>	<input type="text"/>	<input type="text"/>	<input type="text"/>
Lot No.	DP No.	PDP or SP	Nearest Cross Street
<input type="text"/>	<input type="text"/>	<input type="text"/>	<input type="text"/>
Owner's Name	Full Address		
<input type="text"/>	<input type="text"/>		
LICENSEE'S DETAILS			
Full Name	Address for Notices		
<input type="text"/>	<input type="text"/>		
Phone No.	Qualified Supervisor No.	Expiry Date	
<input type="text"/>	<input type="text"/>	<input type="text"/>	
	Licence No.	Expiry Date	
	<input type="text"/>	<input type="text"/>	
WORK OF WATER SUPPLY			
Give full Description of Work carried out			
<input type="checkbox"/> Install Water Supply <input type="text"/>			
<input type="checkbox"/> Install Irrigation system <input type="text"/>			
<input type="checkbox"/> On-site Alternative Water Services <input type="text"/>			
<input type="checkbox"/> Install/Commission/Maintenance of Thermostatic Mixing Valve <input type="text"/>			
<input type="checkbox"/> Connection to water supply <input type="text"/>			
<input type="checkbox"/> Install, alter, disconnect or remove a backflow prevention device <input type="text"/>			
<input type="checkbox"/> Other <input type="text"/>			
<input type="text"/>			
<input type="text"/>			
PLUMBING WORK TO COMPLY WITH <input type="checkbox"/> AS/NZS3500 <input type="checkbox"/> ALTERNATIVE SOLUTION <input type="checkbox"/> COMBINED			
WORK OF SANITARY PLUMBING/DRAINAGE AND SUPPLY DRAINAGE PLAN			
Give full description of work carried out			
<input type="checkbox"/> Carry out work of sanitary plumbing/drainage <input type="text"/>			
<input type="checkbox"/> Connection to Sewer <input type="text"/>			
<input type="checkbox"/> Sewer Disconnection <input type="text"/>			
<input type="checkbox"/> Carry out Trade Waste Drainage <input type="text"/>			
<input type="checkbox"/> Other <input type="text"/>			
<input type="text"/>			
<input type="text"/>			
DRAINAGE WORK TO COMPLY WITH <input type="checkbox"/> AS/NZS3500 <input type="checkbox"/> ALTERNATIVE SOLUTION <input type="checkbox"/> COMBINED			
SEWERAGE/WATER SERVICE INSPECTION FEE			
Date Fee Paid	Date of Commencement of Work	Estimated Date of Completion	
<input type="text"/>	<input type="text"/>	<input type="text"/>	
Amount	Reference No:	Contractors Signature	
\$ <input type="text"/>	<input type="text"/>	<input type="text"/>	

1. In respect of authorised work carried out by me at the above mentioned property I certify that:
 - i. The work corresponds to the specifications in the notice of work.
 - ii. The completed work has been tested as required by the Regulator and has passed such test;
 - iii. Where required by Section 11 of the Plumbing and Drainage Act 2011, I have given written notice of any identified pre-existing defective plumbing and/or drainage work..... Yes N/A
 - iv. The work complies with the relevant Acts, Regulations, Codes and Standards;
 - v. The work was completed on ___/___/___ Contractors Signature _____

2. If any defect is found in the work carried out by me within a period of two (2) years or within the time specified by Regulator, from the date of the final inspection, and the Regulator for Plumbing and Drainage certifies by written notice that in their opinion the defect is due to faulty workmanship or defective materials, then I undertake to rectify such work at my sole expense, if so directed by the Regulator within the time specified by the Regulation.

APPENDIX 4

Typical Rainwater Tank / Plumbing Configurations

Typical Rainwater Tank Cross Section

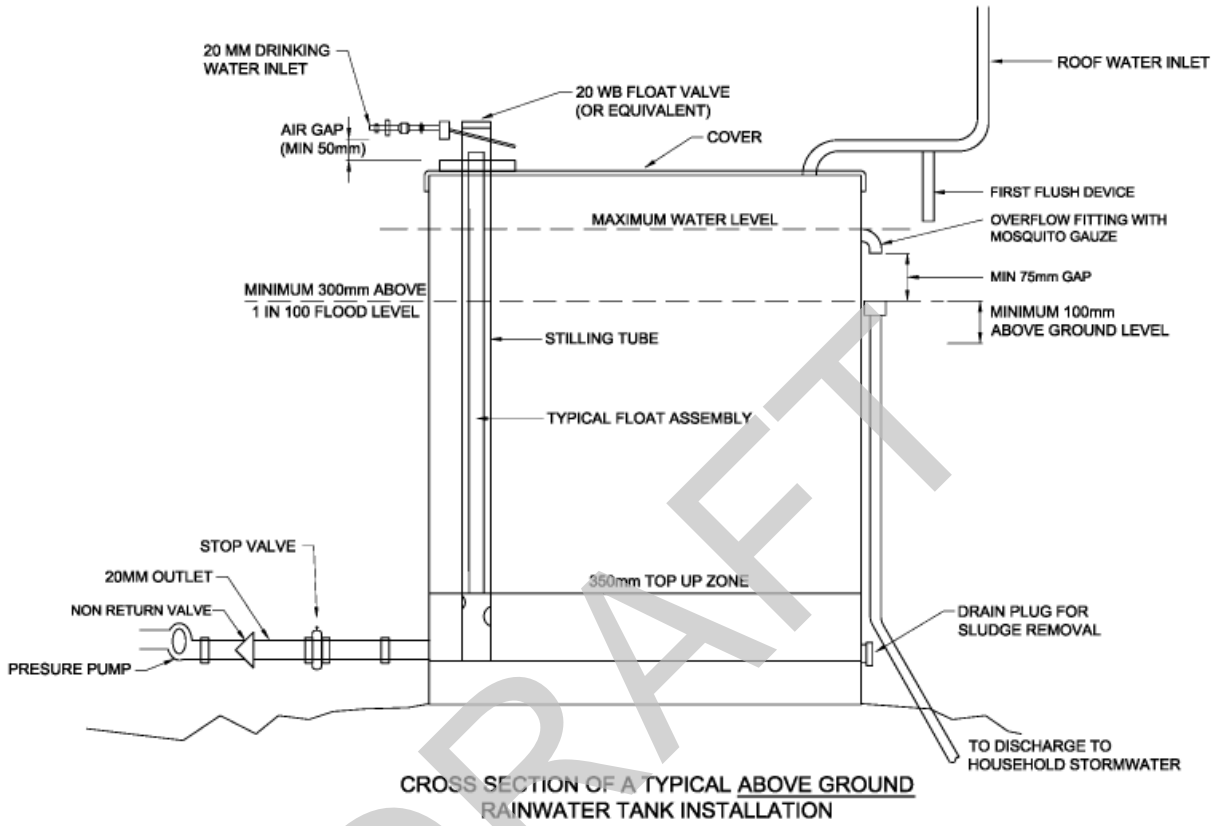

Note: To be considered as an above ground rainwater tank, the outlet of the overflow fitting must be a minimum of 375mm above the 1 in 100 year flood level.

Typical First Flush Device

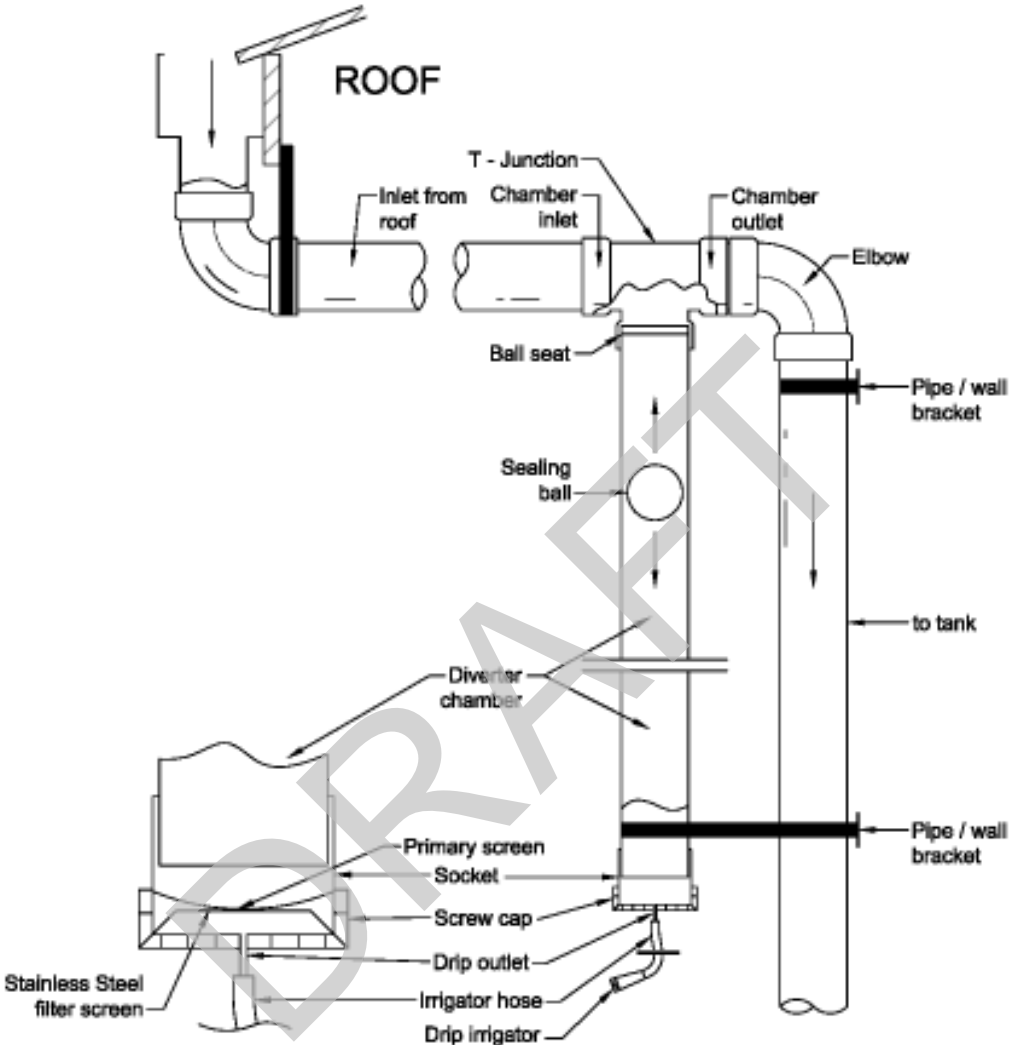

FIRST FLUSH DEVICE

Above Ground Tank with Rainwater Control Valve

(e.g. Rainbank, Rainsaver or similar product)
Providing rainwater to WC, External Hose Tap & Washing Machine Tap

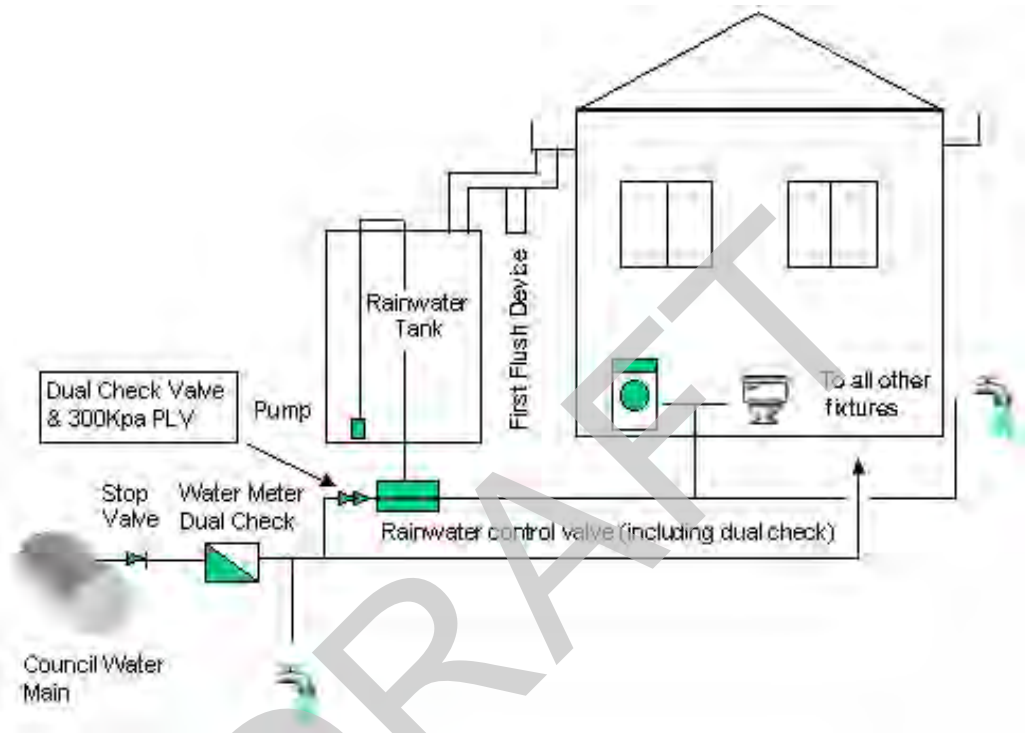

Above Ground Tank with Direct Town Water Interconnection

Providing rainwater to WC, External Hose Tap & Washing Machine Tap

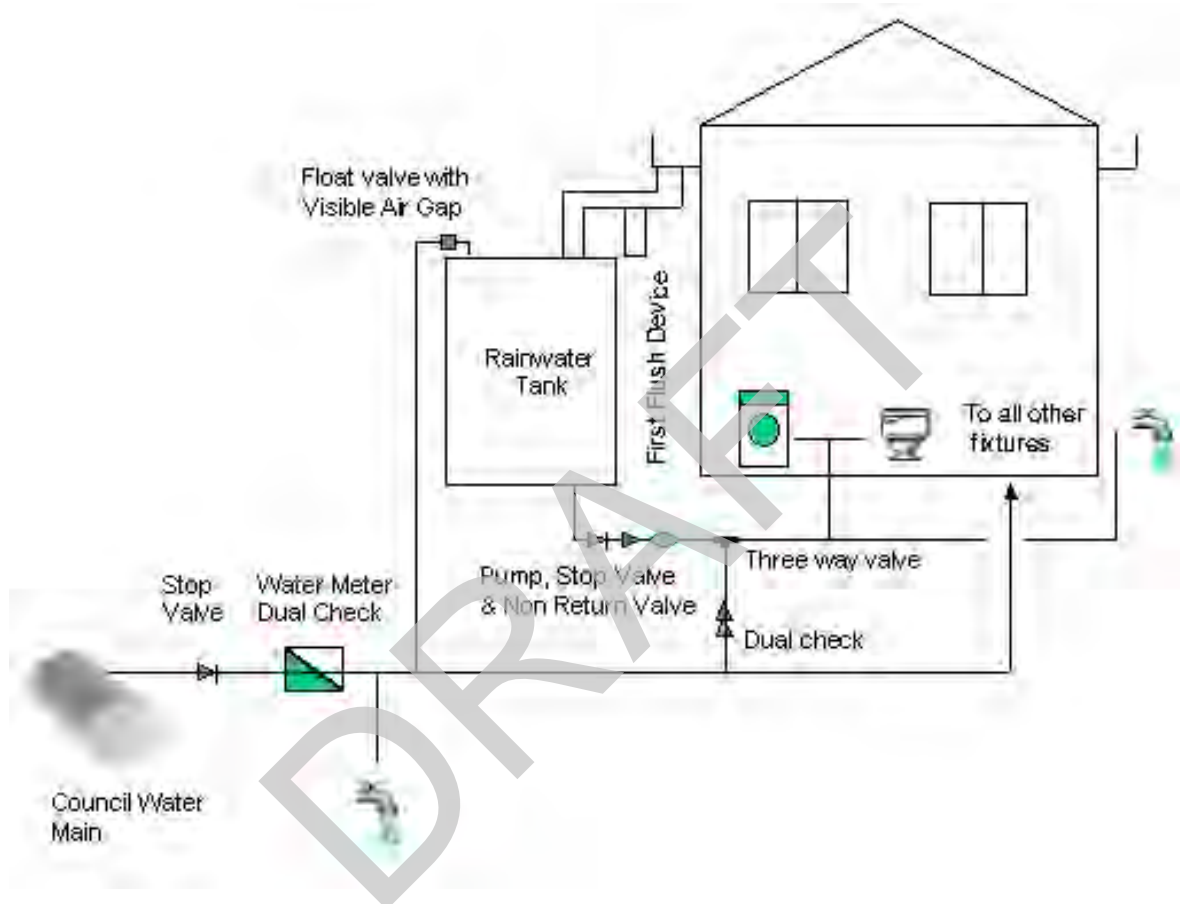

Above Ground Tank with Air Gap (Indirect Town Water Interconnection)

Providing rainwater to WC, External Hose Tap & Washing Machine Tap

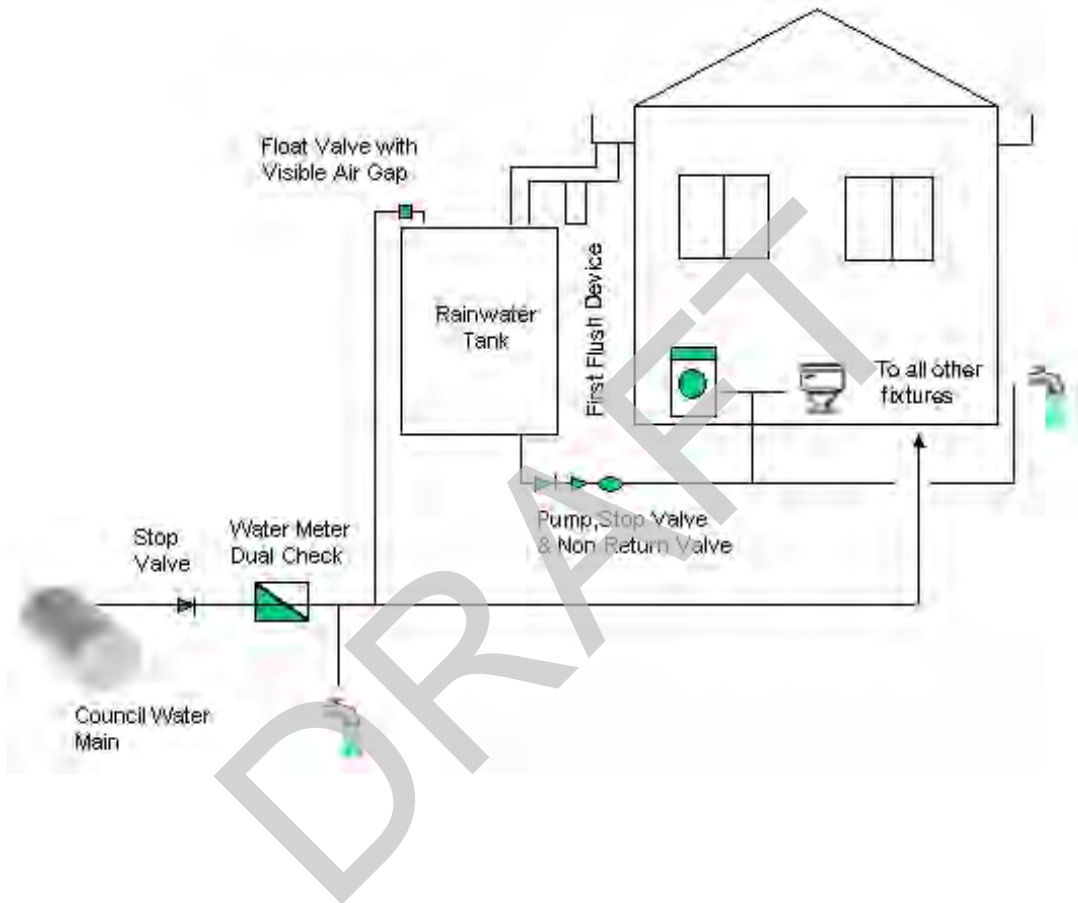

In-Ground Tank with Testable Backflow Prevention

Providing Rainwater to WC, External Hose Tap & Washing Machine Tap

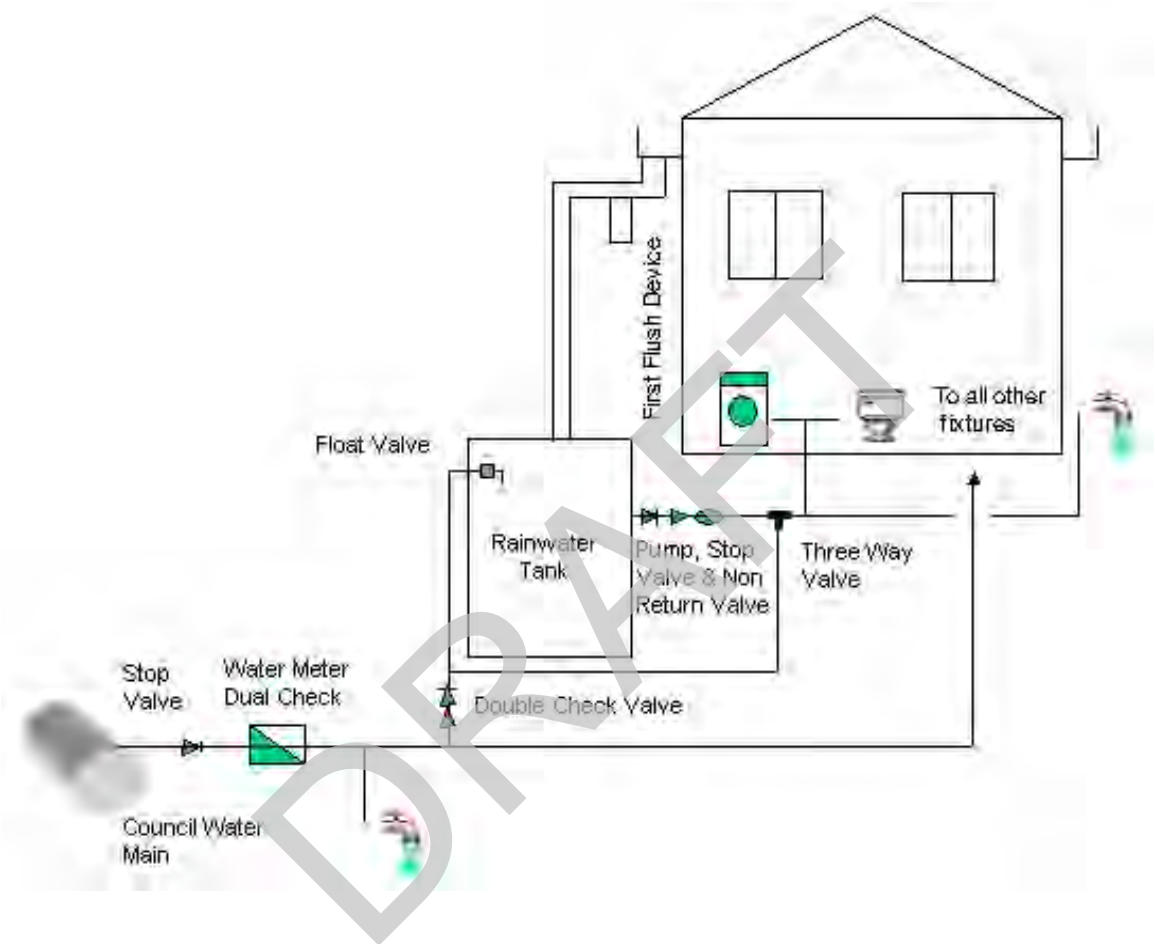

Typical Connection to Washing Machine – No Town Water Interconnection

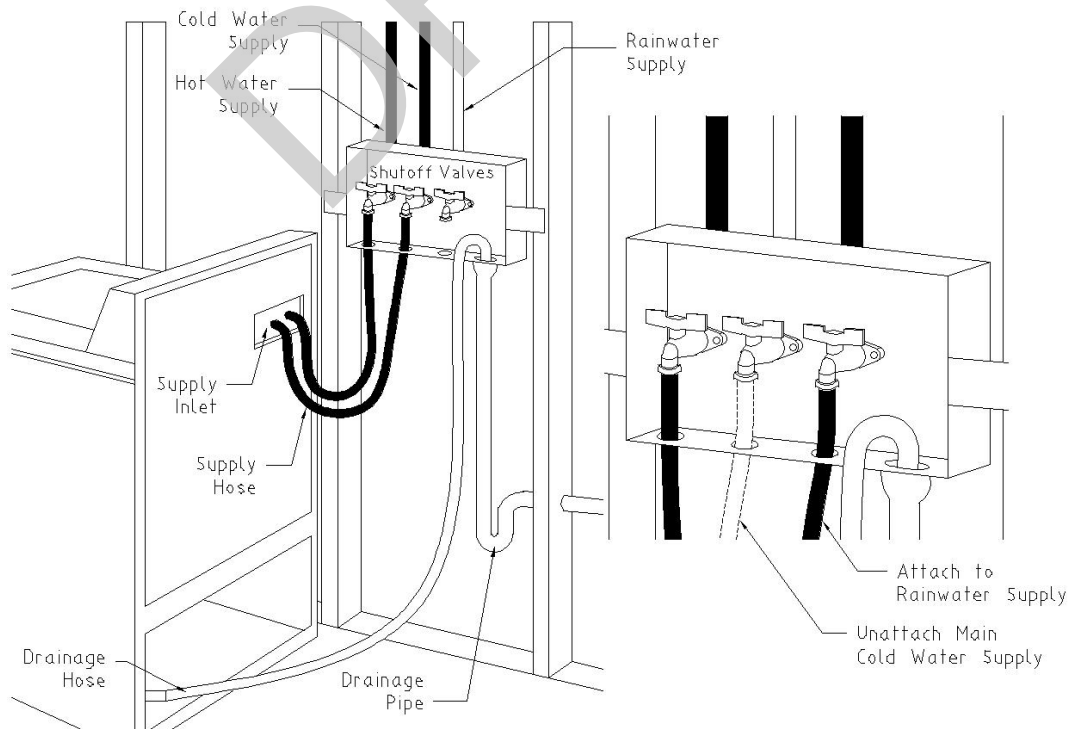
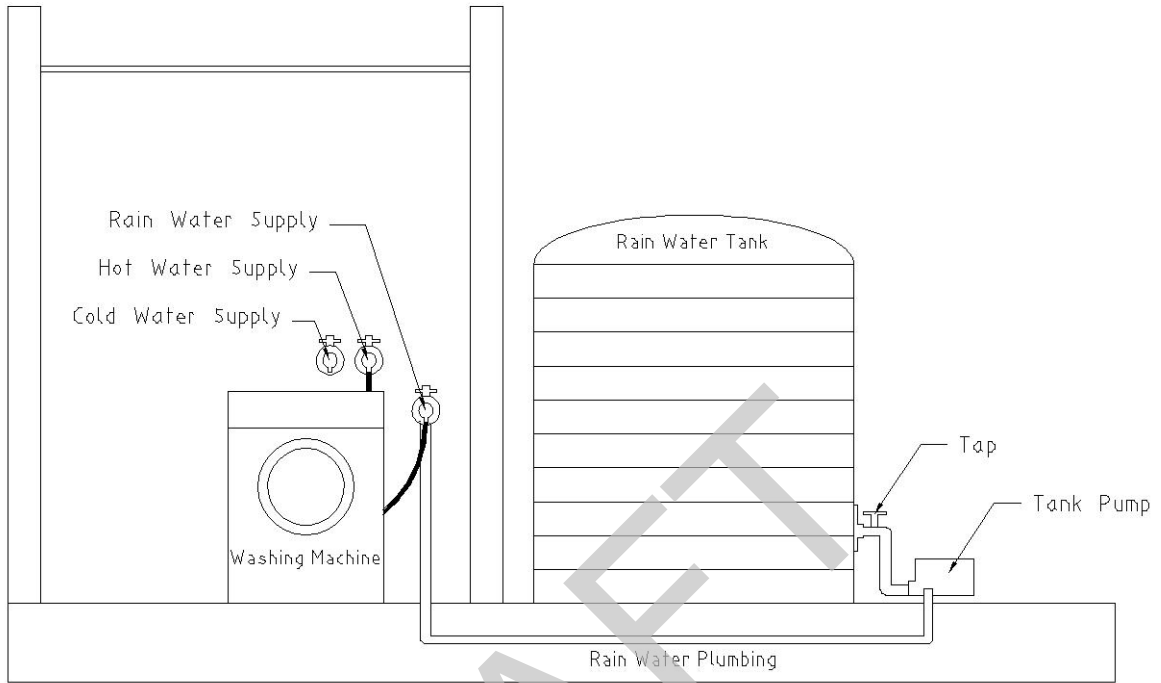

Typical Connection to Toilet Cistern – No Town Water Interconnection

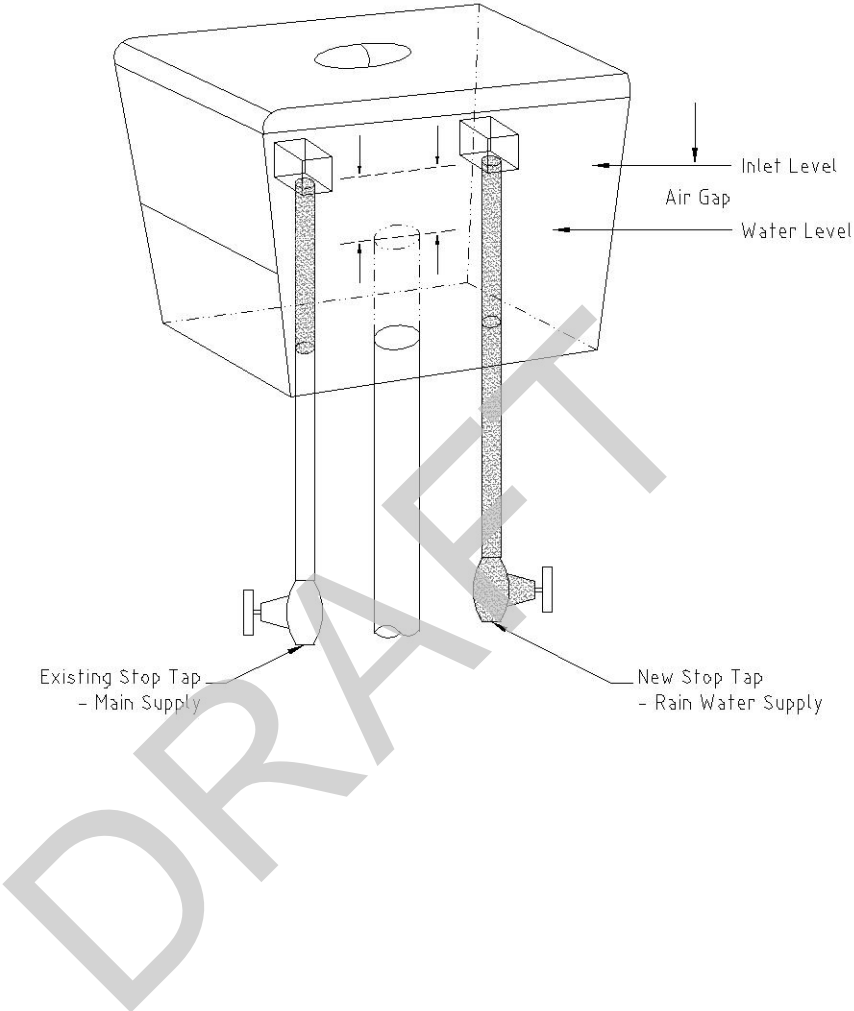

Related Legislation

Not applicable.

Compliance

Not applicable

Forms

Application for Approval of Plumbing and Drainage Work on Private Land
Notice of Work for Plumbing and Drainage Work
Certificate of Compliance for Plumbing and Drainage Work

Review Period

This policy will be reviewed within 12 months of the election of each new Council or more frequently in the event of any legislative changes or change in circumstances.

Useful Links

[Tweed Shire Council website](#)

[Office of Local Government](#)

Australian Government Department of Health and Ageing
<http://www.health.gov.au/internet/main/publishing.nsf/Content/ohp-enhealth-raintank-cnt.htm>

NSW Department of Health
<http://www0.health.nsw.gov.au/publichealth/environment/water/rainwater.asp>

Version Control:

Version History		
Version #	Summary of changes made	Date changes made
2.1	Incorporated into new policy template	20/06/2013
3.0	Extending coverage to non-residential rainwater tanks	18/06/2015
3.0	Adopted by Council	17/9/2015
<u>3.1</u>	<u>Review and minor amendments to references to AS3500 and BASIX information</u>	<u>xxx</u>