SECTION A1 RESIDENTIAL AND TOURIST CODE

DRAFT

SCHEDULE OF AMENDMENTS

Version	Date of Council Adoption	Effective Date	Description
1.0		22.04.2008	Initial adoption by Council
1.1		25.11.2008	Amendment to Area Specific Site Controls to include height and density provisions for Hastings Point – south of Cudgera Creek Bridge.
1.2		21.04.2009	Extension of the Area Specific Site Controls relating to Hastings Point (south of the Cudgera Creek Bridge) to the whole of Hastings Point
1.3		28.04.2009	Repeal of an Area Specific Interim Site Control (density ratio of 1 dwelling per 250m ² of site area) and the inclusion of a new density controls of no more than 2 dwellings (dual occupancy) per site relating to Hastings Point.
1.4	draft	25.10.2012	Best practice five year review of Part A for public exhibition
1.5	final draft	18.04.2013	final draft following public exhibition

DRAFT

PRELIMINARY INFORMATION

CONTENTS

1. Introduction	5
1.1. Purpose of this Section	5
1.2. Land to which this Section applies	5
1.3. Development covered by this Section	5
1.4. Objectives of this Section	5
1.5. How to use this Section	5
1.6. Relationship to other Sections	6
1.7. Use of diagrams within this Section	6
1.8. Non urban zoned land	6
1.9. Pre-development application lodgement meeting	6
2. Building types	8
2.1. Hybrid development	8
3. Dictionary applying to this Section	9
4. Context and site analysis	13
4.1. Streetscape	14
4.2. Views and vistas	16

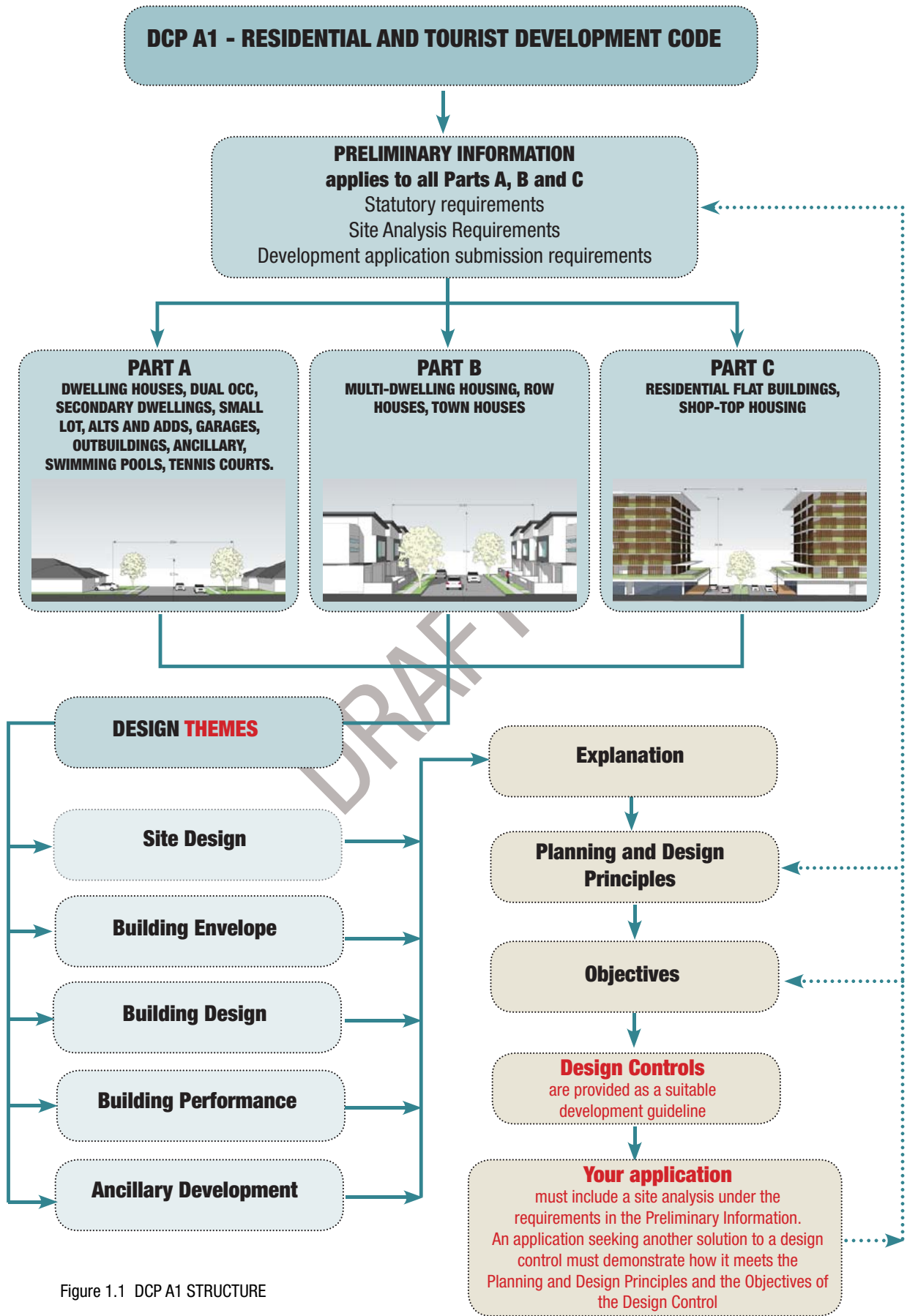

Figure 1.1 DCP A1 STRUCTURE

1. Introduction

1.1. Purpose of this Section

The purpose of this Section is to guide the planning and design of residential and tourist development and development ancillary to residential and tourist development within Tweed Shire.

1.2. Land to which this Section applies

This Section applies to all residential and tourist development within the Tweed Shire, except to the extent of inconsistency with a development provision contained in the Tweed LEP or area specific locality development control plan in Section B.

1.3. Development covered by this Section

This Section is in several Parts and applies to all development associated with the following building types:

PART A applies to dwelling houses, alterations and additions to dwelling houses, **dual occupancy, secondary dwellings**, garages, carports, outbuildings, swimming pools and tennis courts.

PART B applies to multi-dwelling housing and includes: town houses (including villas), and row housing (including terraces).

PART C applies to residential flat buildings and includes: shop-top housing, shop-top residential flat buildings, and residential flat buildings.

1.4. Objectives of this section

The over arching objectives of this section are:

1. Provide for a diversity of types and sizes of residential and tourist related development throughout localities;
2. Ensure that development is compatible with the local natural and built character, scale and amenity;
3. Ensure quality residential and tourist development which responds to the features of the site and the Tweed's subtropical climate; and
4. Encourage development that incorporates the principles of sustainability in design, materials and lifecycle.

1.5. How to use this Section

The Residential and Tourism Development Code ('the Code') is divided into a number of **Design Themes** relating to the site context, the site, the building envelope controls, building design, building performance and ancillary development.

Each **Design Theme** is structured to include:

- an **explanation** of the design criteria and why it is important the design criteria is considered and addressed;
- where relevant, over-arching **planning and design principles**;
- a range of **objectives** to achieve desired outcomes; and
- the **design controls**.

Note: Addressing these criteria is not a mechanism for an automatic variation but rather a process for enabling an assessment of an alternate solution on its merit.

Note: The "Development Application Guide" and a range of development application checklists are available on the Tweed Shire Council website at: <http://www.tweed.nsw.gov.au/Forms>

Council encourages the electronic submission of information as outlined in the Development Application (DA) Checklist on Council's website.

The State Government's State Environmental Planning Policy Exempt and Complying Development Codes (Housing Code SEPP) provides for a range of housing and ancillary development which may be carried out without a development application.

Applicants are advised to consult the Housing Code SEPP to determine whether development requires a DA or can be undertaken as Complying development through a Complying development Certificate (CDC).

This DCP Part does not apply to development undertaken as a CDC. CDC development is to comply with the Housing Code SEPP requirements.

The **design controls** are a development guideline and represent a possible **acceptable** solution to meet the design theme **objectives** and **planning and design principles**. It is **acknowledged** that there may be other **acceptable solutions**. Where a development application seeks an **alternative solution to a design control this must be documented within** the Statement of Environmental Effects (SEE), and include:

- Identification of the design control being varied; and
- Justification, supported by a detailed site analysis:
 - detailing why the design control cannot be met; and
 - demonstrating how the alternate proposal achieves the design theme objectives and planning and design principles.

1.6. Relationship to other Sections

All proposals must be designed to meet the requirements of all other relevant Sections contained within this DCP.

1.7. Use of diagrams within this Section

Illustrations provided in this section are indicative only and are provided to illustrate certain aspects of the plan. The diagrams must not be interpreted, used, or referred to as any form of either prescriptive or performance based control.

1.8. Non urban zoned land

Development on non urban land shall not, for the purpose of this Section, be restricted to the deep soil zone, setback and carport, garages and outbuildings controls where it is demonstrated that compliance with a particular control would be unreasonable in the circumstances. A variation under this circumstance will not be required to comply with the requirements of the variation provision of this Plan.

1.9. Pre-development application lodgement meeting

Applications for any development the subject of Part B or C of this Plan, comprising Residential Flat Buildings, Shop-top Housing, Town Housing, Row Housing or any one of these building types for tourist accommodation, that either includes a variation to a control or where the proponent perceives that a design issue may arise, is strongly recommended to arrange and attend a pre-development application lodgement meeting with Council's Development Assessment Panel (DAP), prior to the lodgement of a development application.

The recommended requirements for a pre-development application and development application submission are provided in Appendix 7.1 - Development application submission requirements.

The matters arising from a DAP Meeting must be addressed in the development application statement of environmental effects under the heading "DAP – Matters Arising".

STEP BY STEP PROCESS FOR A NEW DWELLING UNDER THE NSW HOUSING CODE OR A DEVELOPMENT APPLICATION

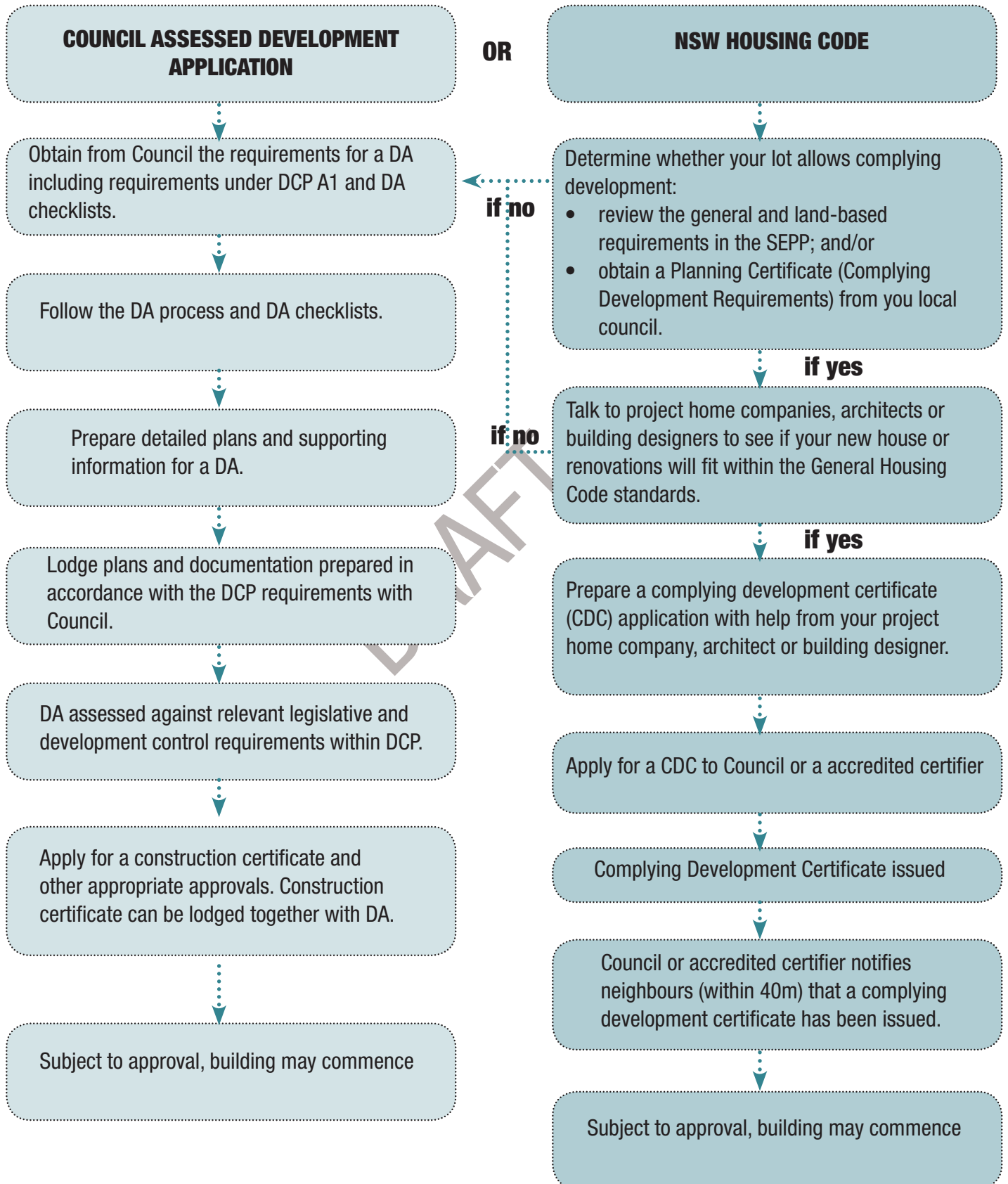

2. Building types

Note: It is noted that the LEP provides a range of maximum development standards, including building height and floor space ratio.

This DCP section does not seek to restrict development which may be permitted under the LEP.

This DCP section does provide additional guidelines for various building types which may be permitted.

The Tweed Local Environmental Plan (LEP) defines the permissible uses within a zone.

This DCP Section further refines the applicable development controls which may apply to those **permitted** residential and/or tourist development building types.

A building type is used to describe building forms and site layouts with common characteristics.

Building types are useful for coordinating the desired character of an area and to ensure buildings achieve dwelling, site and streetscape amenity.

Building type is a tool used to ensure building and site design controls are coordinated to suit a range of common site and development types.

Building types are important as they guide development to be more specific to the following conditions:

- the site size and allotment proportions;
- the relationship to existing built form, subdivision and block context;
- the relationship to the existing streetscape; and
- the site characteristics such as topography and vegetation.

The residential dwelling types identified in this Section are:

- Dwelling Houses (Including ancillary structures) (Part A)
- Dual Occupancy, Secondary dwellings (Part A)
- Town Housing (including villas) (Part B)
- Row Housing (including terraces) (Part B)
- Residential flat buildings (Part C)
- Shop-top Housing (Part C)

2.1. Hybrid development

This plan encourages developments to be comprised of any combination of building types, where the zoning allows.

This can occur on larger sites where a range of building types will be proposed or where the design of a building takes on the characteristics of two building types such as a residential flat building layout that is two storeys ie. a town house.

In such cases and where it is unclear as to what controls to apply the development, the proponent must automatically work to the most stringent control. In the example above, the residential flat building controls, notwithstanding its two storey design, would apply.

It may be at the discretion of Council's Development Assessment Panel to advise when to use the less stringent controls; exercising its judgement based on the site and its particular circumstances.

Note: Where a term is not defined, the DCP relies on the definitions within the applicable Tweed LEP.

3. Dictionary applying to this Section

Access handle: a strip of land forming part of a site whether in fee-simple or right of way, which has the principle function of providing a property access.

Amenity: the livability or quality of a place which makes it pleasant and agreeable to be in for individuals and the community. Amenity is gained from elements such as sunlight, views, privacy, ambiance and the like.

ANEF contour: Has the same meaning as it has within the State Environmental Planning Policy (Exempt and Complying Development Codes) 2008. Reference is also made to *Australian Standard AS2021 Acoustics - Aircraft noise intrusion – Building Siting and Design*.

Articulation Zone: Has the same meaning as it has within the State Environmental Planning Policy (Exempt and Complying Development Codes) 2008.

Attached dual occupancy: means two dwelling-houses that are physically attached by way of a common or shared wall (between internal living areas) or garage but does not include carport, breezeway or the like, open or detachable structure.

Balcony: an outdoor, open or partially enclosed area that is either partially integrated into or protrudes entirely from the outer enclosing walls of a building as a means of providing private open space.

BASIX: introduced as part of the NSW planning system, BASIX (the Building Sustainability Index), is a web-based planning tool that measures the potential performance of new residential dwellings against sustainability indices.

Battleaxe: Has the same meaning as within the State Environmental Planning Policy (Exempt and Complying Development Codes) 2008.

Building envelope: a three dimensional zone determined by height, width, depth and setbacks that defines the buildable area on a site.

Building elevation: the external wall of a building.

Building footprint: is area of the building to the extent of the edge of the roof line.

Circulation core: common areas within a development that provide pedestrian movement within the building.

Climate: in the context of this Plan refers to the climatic zones attributed to the Tweed Shire LGA by the Bureau of Meteorology, comprising subtropical (warm humid) and temperate zones.

Communal open space: a designated shared open space area available to the occupants of more than one residential / tourist dwelling and which is under the control of a body corporate or equivalent.

Colonnade: a semi enclosed sidewalk (the pedestrian part of a public street) enclosing on the top and one side by buildings. The colonnade generally has columns that support the building over the sidewalk located between the sidewalk and the carriageway (the vehicular part of the street).

DCP: refers to a Development Control Plan prepared in accordance with the Environmental Planning and Assessment Act 1979.

Deck: refers to an external platform, usually elevated, located alongside and accessible from an interior space.

Deep Soil Zone: means that area of a site with no above ground level or subterranean development, including driveways, paved surfaces, pathways, or like surface, that serves principally for larger tree and landscape plantings.

Demolition: refers to the damaging, defacing destruction, deconstruction, pulling-down, removal or the like of a building in whole or in part.

Development: has the same meaning as it has in the Environmental Planning and Assessment Act 1979.

Double loaded corridor: is a corridor in a Residential Flat Building with apartments on both sides. These buildings have most apartments with one orientation only.

External living areas: External living area refers to an external space that extends the living and recreation space of a dwelling to form provide private outdoor recreational and relaxation space. These spaces generally take the form of courtyards, decks, terraces and balconies, they can be paved or decked and may be covered. External living areas may be located either on ground or above ground.

Floor Area: Has the same meaning as it has within the State Environmental Planning Policy (Exempt and Complying Development Codes) 2008.

Front fences and walls: refers to fences and walls situated forward of the building façade or within the nominated front building line (setback), whichever is the greater, that are located on the site.

Frontage or primary frontage: refers to the area of abutment between a boundary line between a site and a public street, and in the case of a multi-frontage site the boundary at which the property is addressed.

Habitable room: Has the same meaning as the Building Code of Australia.

Impervious area: means a surface area that does not allow rainwater to penetrate through into the underlying ground.

Indigenous species: refers to a plant or animal species that occurs at a place within its historically known natural range and that forms part of the natural biological diversity of a place.

Infill: Infill development is any allotment that is neighboured or adjoins a property that supports a building, including sites within new subdivisions, where that development has already occurred.

Operable screening device: refers to sliding, folding or retractable elements on a building designed to provide shade, privacy and protection from natural elements.

Outbuilding: Has the same meaning as it has within the State Environmental Planning Policy (Exempt and Complying Development Codes) 2008.

Passive solar design: refers to a design or modification to a building to minimise energy consumption by taking advantage of natural heating and cooling methods.

Roof terrace: refers to the flat roof of a building (or part thereof), which is designed to be used or adapted for open space or recreation purposes for one or more of the occupants of the building, and which is open to the sky.

Secondary (road) street frontage: Has the same meaning as it has within the State Environmental Planning Policy (Exempt and Complying Development Codes) 2008.

SEPP: refers to a State Environmental Planning Policy.

Shadow diagram: refers to a plan illustrating the extent of shadow cast by a specified object or building at predetermined times of the day and year, and that are based on a longitude and Latitude for that site.

Standard Instrument: means the standard local environmental planning instrument prescribed by the Standard Instrument (Local Environment Plans) Order 2006.

Tweed LEP or TLEP: refers to the Tweed Local Environmental Plan.

DRAFT

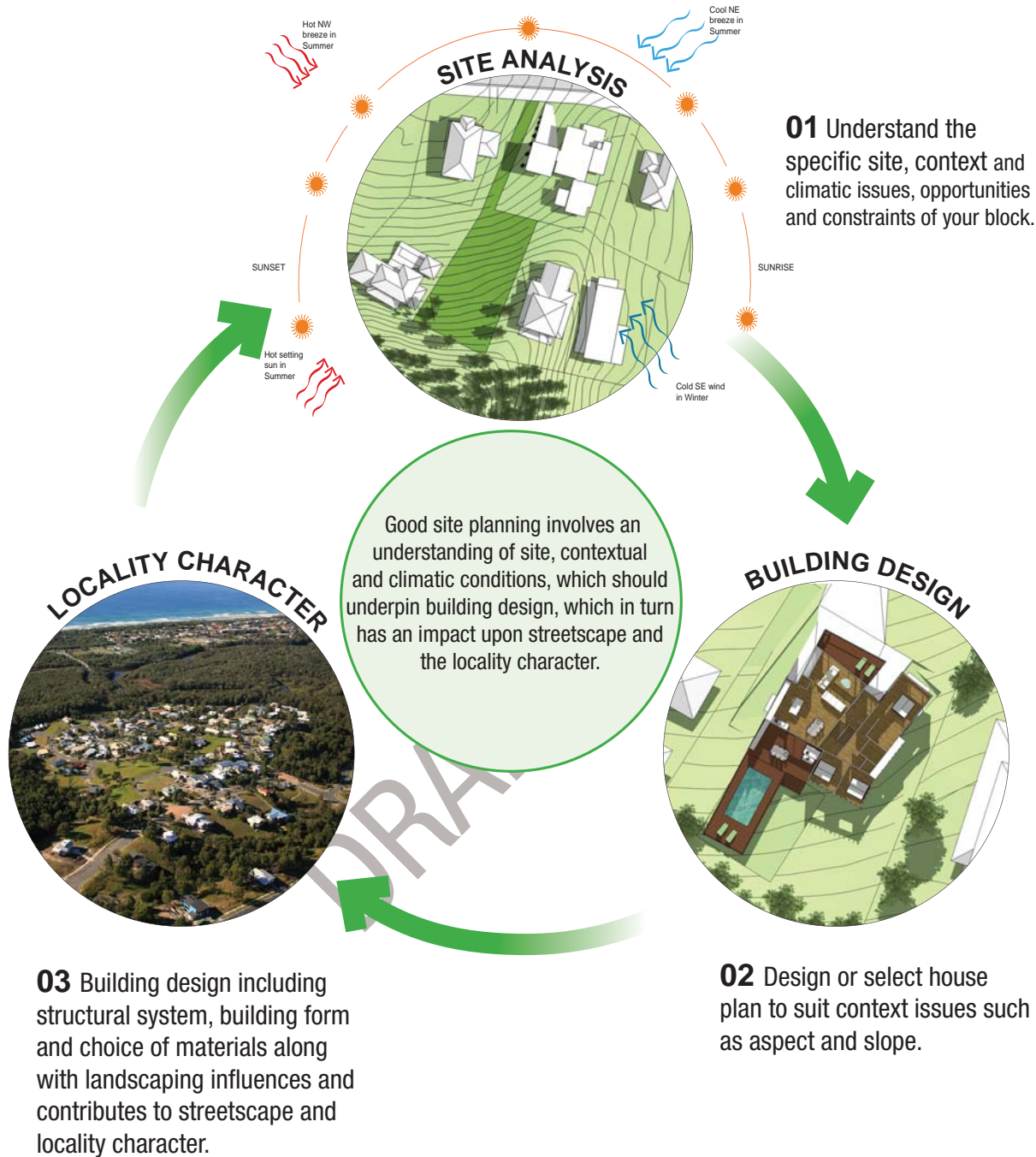

Site Analysis - An integrated site analysis understands the relationship of a particular site within a given context. It looks at opportunities and constraints to ensure this information is used to inform a design outcome. Buildings designed to specifically address topographic and climatic considerations are generally more comfortable to live in.

3. Context and site analysis

The first step in good design is to understand the character and attributes of the site and the locality.

Site analysis and design comprises two parts:

1. assessment of the site and locality and then,
2. developing or selecting a dwelling design that responds to the characteristics of the site and the locality, the opportunities, constraints, unique features or hazards of the site.

Examples of site analysis showing these two parts is provided in Appendix 7.2.

Note: Development that is designed to the site conditions greatly enhances the dwellings amenity, livability and general comfort.

On a broader level understanding and responding to the site enhances the sense of place, reinforces the role and character of the Tweed localities, improves the quality of the environment for the community and ensures that the proposed development is the best possible solution and makes the best contribution to its surroundings.

Development designed within this context is also cheaper to operate and maintain, reducing reliance on artificial lighting and mechanical heating and cooling.

Note: A site analysis template is available on Council's website to assist in preparing the site analysis documentation.

It is noted the degree of detail required will vary according to the nature, type and scale of the proposed development, its surroundings and potential amenity impacts.

Planning and design principles

Buildings designed to respond to a site and context demonstrate the following key principles:

- P1. Demonstrates that the site analysis has been used in preparing or selecting the design for the site and that due consideration has been given to the opportunities and constraints of the site and its context.
- P2. The design is climate appropriate and responsive.
- P3. Respects the topography and landforms of the site and locality.
- P4. Understands that each dwelling built within a street builds up the "character of the Tweed".
- P5. Values, protects and shares views and landscape vistas.
- P6. Minimises issues relating to noise transfer, overshadowing and overlooking, safety, access, views and privacy.

Objectives

- O1. Ensure the opportunities and constraints of a site and its surroundings are comprehensively considered and inform the proposed dwelling design or selection.
- O2. Ensure that development embodies best practice site planning principles and makes a positive and harmonious contribution to its surroundings.
- O3. Ensure the proposal results in a dwelling that is sensitive to its built and natural environment context, **the unique features and hazards of the site** and is of high design quality.
- O4. Ensure that the dwelling is designed and sited appropriately for the Tweed's temperate sub-tropical climate.

Controls

- C1. A site analysis, including details as relevant but not limited to the criteria in the Site Analysis Checklist (Appendix 7.3) is required for all dwelling development applications involving external building work, and is to demonstrate how the proposed development responds to the site analysis. Minor development (such as extensions, minor renovations) may only require a partial site analysis for the affected area of the site.

3.1. Streetscape

Designing and constructing a dwelling should not be considered in isolation of understanding the character of its locality. The context relates to those aspects of the urban environment which are enjoyed by the public and include neighbourhood character, streetscape character, public views and vistas.

New developments, alterations and additions can contribute positively to the neighbourhood and streetscape character. In established residential areas it is important to recognise and respect the existing qualities and unique characteristics of the place. In locations where the character is either not well established or needs improvement, new development can contribute to strengthening and creating character.

Building orientation is also a key aspect in ensuring that development responds to the streetscape, seeks to ensure privacy and outlook for dwellings and to protect the amenity of neighbouring dwellings.

Planning and design principles

Dwellings which create and contribute positively to streetscape character demonstrate the following key principles:

- P1. Dwellings 'sit' comfortably within the streetscape by way of integrating design with topography and establishing a strong and engaging address to the street.
- P2. Understand and address the relationship between street width and streetscape scale with an appropriate dwelling form and scale.
- P3. Understand and respond to the characteristics of existing dwellings within the street including built form rhythm, setbacks, roof forms, materials, point of access, driveway design and prominence of garaging.
- P4. In existing residential areas the established orientation of dwellings is to the front and the rear of lots. It is important that new or infill development respects and integrates within this pattern so as to fit within the established context.
- P5. Consider the form and impact of the new dwellings size and shape, elevations, setbacks, height, and roof within the streetscape and on the adjoining properties.
- P6. Consider the internal and planning to promote spaces and decks that overlook and are orientated towards the street providing a strong street address and passive surveillance opportunity.
- P7. Consider the relationship of the dwelling and its yard spaces within the streetscape to ensure a positive contribution of dwelling house and garden materials, front and side fencing and landscaping to the street.

Note: Streetscape refers to the spatial arrangement, extent and appearance of elements within a street, which includes some elements on private properties adjoining the street. Streetscape design seeks to ensure there is consistency in the built and landscape form along streets on private sites, ensure that dwellings and their gardens relate well to each other and to the landscape setting along the street and that residential development integrates with and contributes to the streetscape character.

Objectives

01. To ensure new development is compatible with, and complements the positive characteristics of the existing built, landscape and topographic elements of the streetscape.
02. To ensure residential development encourages a high level of pedestrian amenity, access, safety and passive surveillance to and along the street.

Controls

- C1. All dwellings should address and offer passive surveillance over the street by ensuring important elements such as front doors, building entry areas and windows are prominent in the building facade (including secondary dwellings) with the entrance clearly identifiable from the street.
- C2. Site design, building setbacks and the location and height of level changes are to consider and be compatible with other buildings and sites along the street, particularly those that are older and more established.
- C3. Corner buildings are to address both street frontages.
- C4. Building design is to consider the contribution of facade elements on the streetscape, including:
 - i. Coordinating and integrating building services, such as drainage pipes, with the overall facade design;
 - ii. Integrating the design of architectural features, including stairs and ramps, and garage/carport entries with the overall facade design, and by locating car parking structures on secondary streets where possible;
 - iii. Ensuring entrance porticos and other articulation zone features are single storey or of a scale relative to the building; and
 - iv. Include screening to exposed undercroft areas particularly those visible from the street.

Note: Also refer to streetscape controls in the context of landscape controls (Section 2.2) and garage and carport design (Section 4.7).

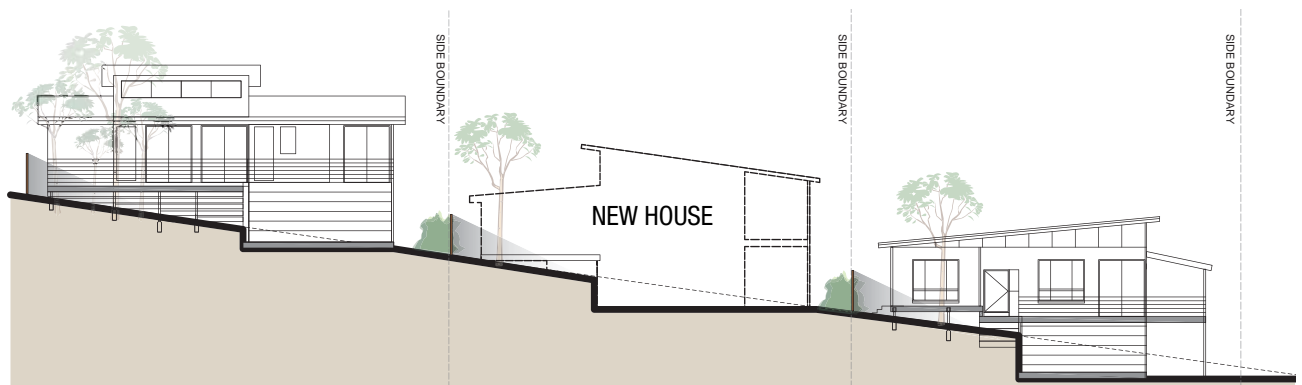

Streetscape - The design of new development should take reference from the existing and desired future streetscape character in terms of existing topographic condition, building and landscape design.

3.2. Views and vistas

The wide mountain and river panoramas of Tweed are an integral part of the Tweed character and highly valued by the community. The Tweed Green Cauldron (the Mt Warning Caldera) is recognised by the Australian Government as a 'National Iconic Landscape'. It is essential that these iconic views and vistas are protected.

Public views and vistas are enjoyed from public places such as foreshores, parks and along streets. Views are generally contained by buildings in the streetscape, such as view corridors down a residential street. Vistas are long wide views, generally across a locality. Vistas are generally defined by ridgelines and valleys.

View sharing is achieved where new dwellings, alterations and additions are designed so as to achieve views whilst retaining the private views enjoyed from existing dwellings on neighbouring sites.

Objectives

01. To ensure existing public views and vistas particularly those of important natural features such as ridgelines, water or bushland, are retained in so far as it is practical to do so.
02. To ensure public view corridors, particularly those down streets and between buildings, are not unnecessarily reduced or obliterated.
03. To ensure public views of important public places or buildings are protected.
04. To protect the iconic scenic landscapes of the Tweed.
05. To have regard to the "Tweed Scenic Landscape Evaluation".
06. To ensure dwellings respect important views from living areas and rooms within existing neighbouring dwellings and employs the principles of view sharing.

Note:

The "Tweed Scenic Landscape Evaluation" is available on Council's website

Note:

**A scenic impact assessment may be required where development intrudes within scenic landscape vistas.*

Also refer to Planning Principles relating to view sharing and assessment of view impact which can be accessed at:

http://www.lawlink.nsw.gov.au/lawlink/lec/ll_lec.nsf/pages/LEC_planningprinciples

Controls

- C1. Building siting and height is, as far as it is practical, to be designed to minimise the impact on views from surrounding properties, and follow the Planning Principles (refer note) of view sharing between properties.
- C2. The location and height of new development is not to significantly diminish the public views to heritage items, dominant landmarks, public buildings from public places or unreasonably obscure public district views of major natural features such as the water, ridgelines or bushland.*

PART A - DWELLINGS HOUSES, DUAL OCCUPANCY, SECONDARY DWELLINGS, ALTERATIONS AND ADDITIONS AND ANCILLARY DEVELOPMENT

1. Introduction	19
1.1. Purpose of this Part	19
1.2. Development to which this Part applies	19
1.3. Structure of this Part	19
1.4. Building types	19
2. Site design	24
2.1. Topography, cut and fill	24
2.2. Landscaping, deep soil zones and external living areas	30
3. Building envelope controls	37
3.1. Setbacks	37
3.2. Building height	46
3.3. Site coverage	49
4. Building design	51
4.1. Designing for the Tweed climate	51
4.2. Passive design	52
4.3. Solar access and natural ventilation	54
4.4. Building form	55
4.5. Visual and acoustic privacy	56
4.6. Roofs, dormers, attics and skylights	58
4.7. Garages, driveways and car parking	59
5. Operational requirements	61
5.1. Waste management	61
6. Ancillary development	62
6.1. Fences and walls	62
6.2. Outbuildings	66
6.3. Swimming pools and spas	67
6.4. Tennis courts	68
7. Appendix	69
7.1. Development application submission requirements	72
7.2. Site analysis checklist	74

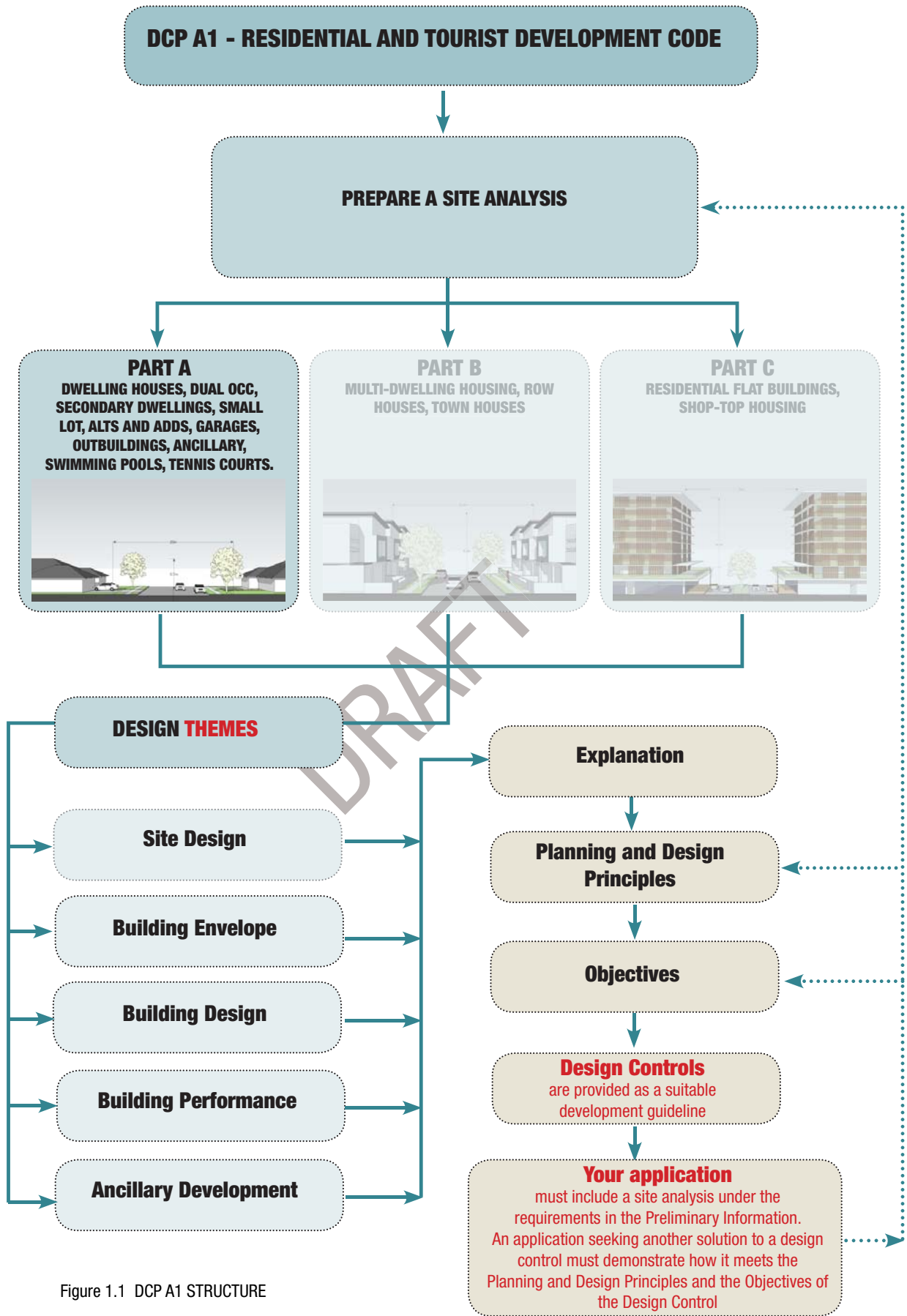

Figure 1.1 DCP A1 STRUCTURE

1. Introduction

1.1. Purpose of this Part

The purpose of this Part is to guide the planning and design of dwelling houses, **secondary dwellings, dual occupancy**, alterations and additions to these forms of housing and development ancillary **to these forms of housing** within Tweed Shire.

1.2. Development to which this Part applies

This Part applies to all single dwelling, **secondary dwellings and dual occupancy** residential and tourist development within the Tweed Shire, except to the extent of inconsistency with a site specific development provision contained in the Tweed LEP or adopted area specific locality development control plan in Part B.

1.3. Structure of this Part

This Part is broadly divided into the following design controls:

- Site Design;
- Building envelope controls;
- Building Design;
- Building Performance; and
- Ancillary Development.

Each of the design themes contain a range of design principles, informing the objectives which underpin the design controls.

1.4. Building types

Part A of DCP A1 relates to:

- Dwelling houses;
- Dual occupancies;
- Secondary dwellings;
- Small lot housing;
- Alterations and additions; and
- Ancillary development.

Part A Planning and design principles

- P1. **Liveable** dwellings provide a high level of residential amenity for residents and contribute to the character of the street and the surrounding suburb, whilst not unduly affecting the amenity of neighbouring dwellings or allotments.
- P2. **Liveable** dwellings are those that have been designed to suit the specific conditions of a given site through a process of site analysis and site planning, building orientation, structure and material selection and integration of landscape.
- P3. Dwellings within the Tweed respond to the sub-tropical climate, high scenic value and sloping topography.
- P4. Small lot housing is best located within or directly adjoining centres, ensuring a balance between density and accessibility.
- P5. Small lot housing has a strong relationship with the street. Rear garages and vehicular access is encouraged for small lot housing which typically has narrower street frontages.

Part A Objectives

01. To ensure development responds to the characteristics of the site and the qualities of the surrounding **built and natural** contextual environment.
02. To achieve environmentally, economically and socially sustainable development.
03. To encourage innovative design for all forms of residential development which is of a high standard of architectural design and merit.
04. To provide a diversity of housing types and sizes within residential areas that meet the needs of the wide range of family and household types and encourages greater availability of varied and affordable housing.
05. **To provide opportunity for** small lot housing **which is** sensitively designed to mitigate amenity impacts on the subject block and adjoining development.

Part A Controls

General

- C1. Dwellings and development must be consistent with the scale and character of surrounding dwellings or as envisaged through an adopted concept plan, locality plan, design statement / covenant or the like.

Dual Occupancies

Note:

During the transition period and for the purposes of understanding development types the Tweed LEP 2000 2(b) Medium Density Residential zone translates to the R3 Medium Density Residential zone in the draft Tweed LEP 2012 under the Standard LEP Template.

A condition requiring the creation of a restriction as to user on the Lands Title, in accordance with the Conveyancing Act 1919, for the purposes of prohibiting subdivision of the development will be imposed on any secondary dwelling development consent.

Secondary dwellings are exempt from payment of contributions in accordance with Section 94 of the Environmental Planning and Assessment Act, 1979 and Section 64 of the Water Supply Authorities Act, 2000.

For maximum floor area of a secondary dwelling, refer to the LEP.

*A secondary dwelling of similar size to the primary dwelling **will be considered and assessed** as a dual occupancy.*

The creation of small lots may require a planning proposal to amend the minimum lot size development standard for a given land zone.

- C2. Dual occupancies are considered as two separate dwellings, each of which are required to meet the requirements setout in Part A.
- C3. Dual occupancy developments on residentially zoned land must be located:
 - on sites with a minimum area of 900m², or
 - on a minimum area of 450m² if the land is within the Medium Density Residential zone.
 - **on a minimum area of 500m² if the land is within the low density residential zone and within 300m of a business zone.**
- C4. Dual occupancy developments must not be located on battle-axe lots.
- C5. In all dual occupancy developments, applicants are to nominate front, rear and side boundaries and apply setback and landscape area requirements accordingly. The nomination of these boundaries, setbacks and configuration of the development is to be justified through a site analysis.
- C6. Mirror image dual occupancy or replication of identical facades is generally discouraged unless it forms part of an overall architectural composition.
- C7. Dual occupancy on non-urban zoned land is not restricted by landscape area, setback, carport, garages and outbuildings controls.

Secondary dwellings

- C8. Secondary dwellings are ancillary to the primary dwelling and are only permitted on allotments which have a site area of more than 450sqm.
- C9. Subdivision of a secondary dwelling development is not permitted. This includes strata, torrens and community title forms of subdivision.
- C10. For the purposes of calculating car parking, landscape (including deep soil zones) and site coverage the secondary dwelling shall be considered collectively as part of the main dwelling.

Small Lot Housing

- C11. Small lot housing must have a minimum lot size of 200m².**
- C12. Small lot housing development must demonstrate walkable proximity to a range of services, facilities, public transport and recreational areas through a site analysis.
- C13. Small lot dwelling design should contribute positively to the streetscape by maximising verandahs or balconies at the front activating the dwelling frontage and interaction with the street.
- C14. Garaging to small lot housing is encouraged to be provided from a rear laneway.**
- C15. Small lot housing development must demonstrate how it integrates with the adjoining lots and surrounding locality.**

INDICATIVE CONFIGURATION - SMALL LOT HOUSING

8.0m

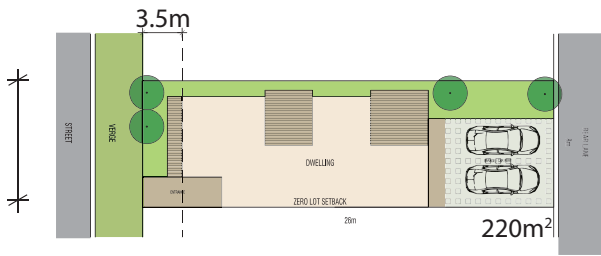

Single storey Detached House

2 bed plus home office to street
Rear loaded car park doubles as courtyard
Zero setback to south
3.5m front setback
North facing decks and nooks

10.0m

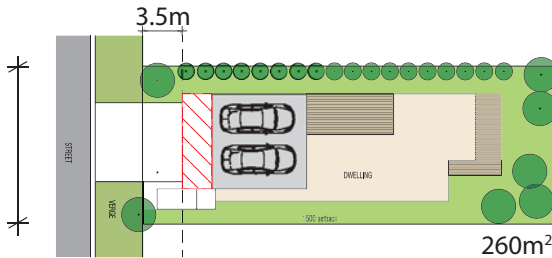

2 storey Detached House

Street car access under projecting upper level deck
1.5m side setback to north and south
3.5m front setback (deck in articulation zone)
North facing decks and nooks

10.0m

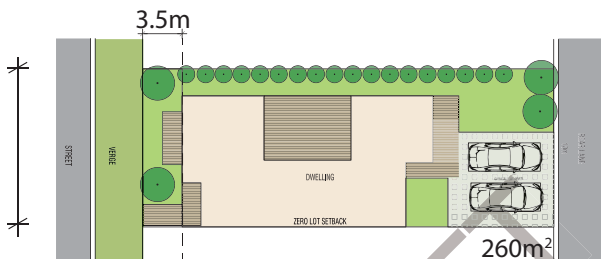

2 storey Courtyard House

Rear loaded car park doubles as extension of outdoor amenity space
Zero side setback to south (part of integrated housing development) allows deeper internal courtyard
3.5m front setback (deck in articulation zone)
North facing decks and nooks

10.0m

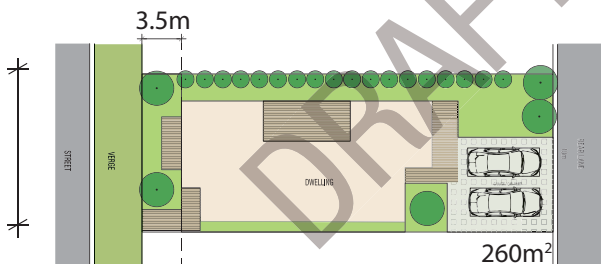

2 storey Courtyard House

Rear loaded car park doubles as extension of outdoor amenity space
1.5m side setback to north and south
3.5m front setback (deck in articulation zone)
North facing decks and nooks

12.0m

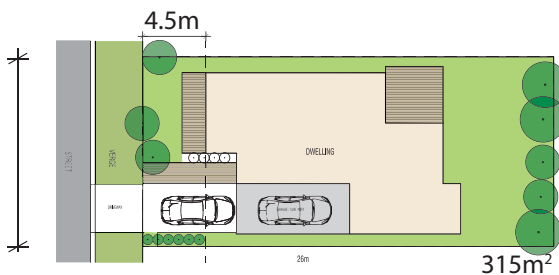

Single storey House

Front tandem or stacked parking (5.5m setback)
900m side setback to north and south
4.5m front setback (deck in articulation zone)
North facing decks and nooks

15.0m

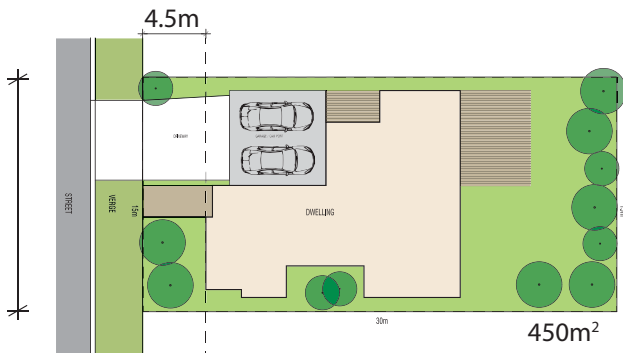

2 storey Detached House

Front car access setback
Deck over recessed garage
1.5m side setbacks
4.5m front setback
North facing decks and nooks



2. Site design

Site design provides a range of criteria to be considered when planning a dwelling, alterations or additions. Site design criteria includes:

- Topography, cut and fill; and
- Landscaping

2.1. Topography, cut and fill

Tweed Shire has significant and varied topography which forms an integral part of the Tweed character. It provides a variety of views and vistas, both local and distant, from public and private domains, which should be an integral consideration of the design or choice of new dwellings.

Development on the steeper and higher topographical areas is often more prominent, particularly when viewed from the low side. Well considered design ensures dwellings integrate with the streetscape and retain a consistent relationship to the natural topography. This relationship provides an important visual link between buildings in a streetscape, as well as reducing the impacts of new development on neighbouring lots.

Deep excavations, cut and fill or benching can substantially alter the landscape character of the Tweed. This may also alter the pattern of subsoil water flow and soil stability, which may adversely affect neighbouring properties and the natural environment.

Alternatives to slab on ground construction are to be encouraged where, due to the gradient and characteristics of the site, major excavation or filling as a result of single raft slab construction would be inappropriate.

Planning and design principles

In order to ensure the protection of the integrity of the Tweed topography and scenic landscapes, buildings incorporate the following key principles:

- P1. The building is designed to 'suit the site' rather than the site 'modified to suit a building'.
- P2. Construction of buildings and construction /structural system maintain the integrity and rhythm of the natural topography.
- P3. Changes in level are incorporated within the footprint of the building rather than at the site boundaries.
- P4. Changes in level outside of the building footprint are landscaped to mitigate visual impacts.
- P5. Development is designed incorporating alternatives to full width and/or depth site benching.
- P6. Buildings generally step with the natural topography in order to remain under the height limit and in order to avoid excessive cut and fill.

Note:

In this context 'rhythm' means the pattern and flow of buildings and topography within the locality and/or streetscape.

Objectives

01. To maintain the integrity of the topographic and scenic landscapes of the Tweed by limiting the extent of excavation, cut, fill and site benching.
02. To moderate the effects of building height, bulk and mass on sloping land.
03. To ensure that the building siting, design and construction method is appropriate for site slope.
04. To mitigate the issues of overlooking, overshadowing and drainage arising from level changes particularly at lot boundary interface.

Controls

- C1. Where earthworks are proposed within the building footprint, construction shall be generally consistent with following requirements:

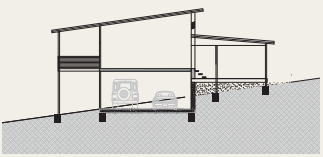
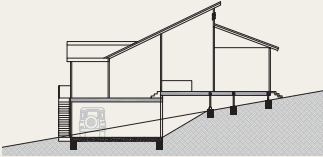
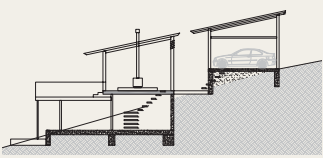
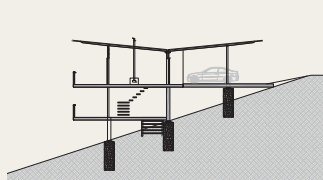
Slope, construction and cut and fill controls					
Slope		Cut allowance	Fill allowance	Appropriate Structure	Indicative Diagram
0-6°	0-10%	1.0m	1.0m	<ul style="list-style-type: none"> • Single slab on ground • Split slab • Post and beam • Hybrid slab post and beam 	
6-8°	10-14%	2.0m within the footprint of the building*	1.0m	<ul style="list-style-type: none"> • No single slab on ground • Split slab • Post and beam • Hybrid slab post and beam 	
8-12°	14-21.5%	2.0m within the footprint of the building*	1.0m	<ul style="list-style-type: none"> • No single slab on ground • Split slab • Post and beam • Hybrid slab post and beam 	
12-18°	21.5-32.5%	3.0m within the footprint of the building*	1.0m	<ul style="list-style-type: none"> • No single slab on ground • Split slab • Post and beam • Hybrid slab post and beam 	
>18°	>32.5%	1.0m	1.0m	<ul style="list-style-type: none"> • No single slab on ground • Downslope construct only • Split slab • Post and beam • Hybrid slab post and beam 	

*Building footprint is defined as the most outer edge of the roof (including fascia and gutter).

Table 1 - Cut and Fill Requirements

Note:

Some steeply sloping allotments won't be able to achieve the rate of +/-1.0m over 10% of the site to a maximum of 100sqm. In this situation outdoor amenity areas may need to be supplemented by decks and other forms of constructed outdoor living space.

- C2. Outside of the building footprint cut and fill to 1.0m for up to 10% of the site or a maximum of 100sqm is permissible to achieve flatter backyards, outdoor living areas, bbq areas, clothes drying areas and the like. On steeply sloping sites (12 degrees and over) consideration may be given to greater cut and fill thresholds subject to:
- i. Justification and satisfaction of the proposal against planning and design principles and objectives of this section;
 - ii. Justification of the proposal and design intent through a site analysis including consideration of the likely streetscape impacts and compatibility with existing streetscape character;
 - iii. Demonstration of a structural system of the house appropriate to the site and slope;
 - iv. Justification and documentation of full site sections showing all existing and proposed levels and proposed retaining walls and batters;
 - v. Consideration of the likely amenity impacts including overlooking, overshadowing, drainage and structural issues;
 - vi. Limiting multiple retaining walls to 1.0m encouraging terracing rather than one large wall;
 - vii. Landscaping to mitigate visual impacts of retaining walls and batters;
 - viii. Suitable stormwater and drainage management.
- C3. Excavations and fill in excess of 1 metre may be permitted to allow for compliant driveways and basement garages providing the excavations are adequately retained and drained in accordance with engineering requirements.
- C4. The interface of the proposed building cut and fill and the natural slope is to be documented on all development plans and sections including the existing and proposed slope of the site levels, all proposed batter and retaining works and where appropriate the interface with adjoining properties. All levels are to be depicted in Australian Height Datum (AHD).
- C5. Cut and fill batters and retaining walls outside of the building footprint are to be landscaped to mitigate visual impacts.
- C6. Cut and fill batters shall not:
- i. exceed a slope of 1:2 (v:h) unless geotechnical reports result in Council being satisfied with the site stability. All batters are to be provided with both short term and long term stabilization to prevent soil erosion.
 - ii. be located where the toe of any battered fill (or retaining wall) is closer than 900mm for cut and 1.5m for fill to any property boundary, where the overall height at any point exceeds 500mm.
 - iii. be located where they will impact on the privacy of neighbours.
 - iv. shall not extend onto Council's road reserve.

- C7. Retaining walls, unless constructed for the sole purpose of landscaping, should be constructed of a material such as concrete, masonry, rock or other permanent type material. Timber retaining walls are not acceptable for walls that support side boundaries or structures.
- C8. Where more than one retaining wall is required, this should be in the form of terracing with landscaped areas between level changes to soften the visual impact of the retaining wall.
- C9. On side sloping allotments where there are existing inter allotment retaining walls, further retaining walls within the side setback will be limited to 600mm.
- C10. Where a property is burdened by stormwater or water and sewerage mains then Council will generally preclude any excavation or filling within that easement.

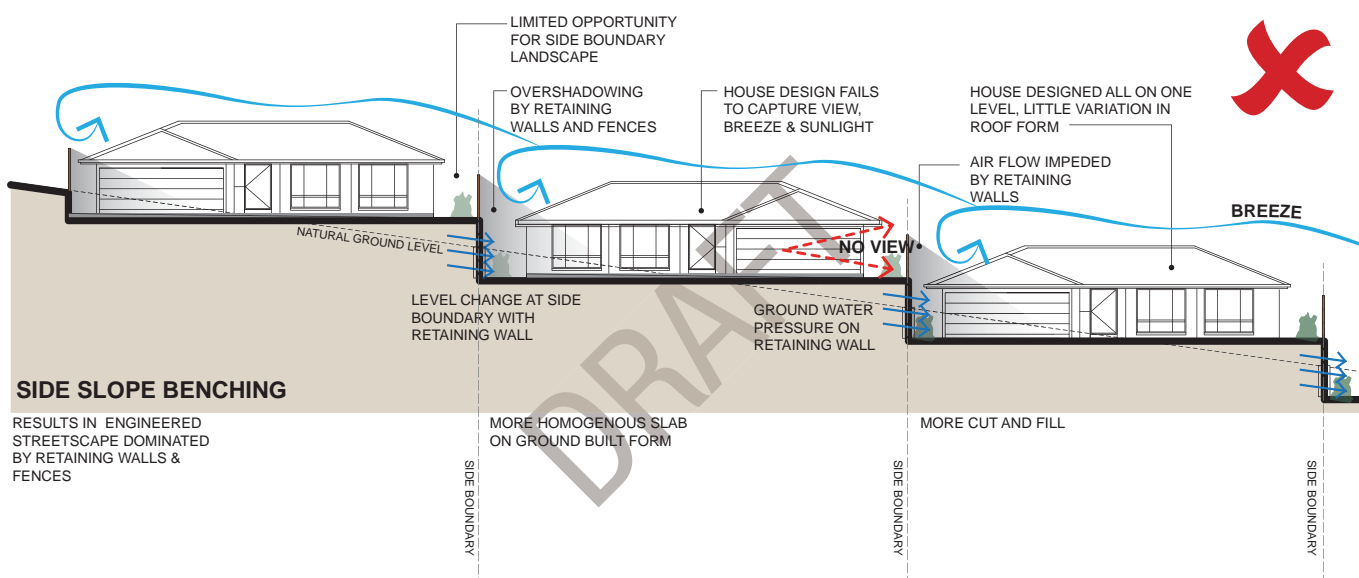

Cut and fill resulting in full width site benching is not desirable as this is altering the topographical character of the Tweed.

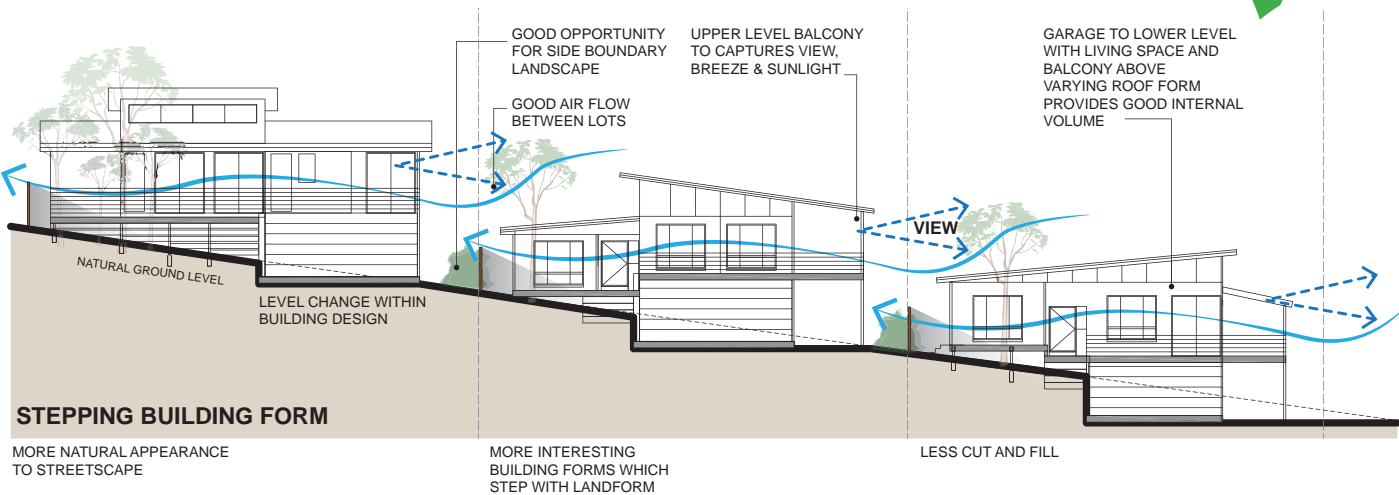

Housing design that responds to the sloping topography and rhythm by incorporating level changes within the building footprint is the preferred solution as it retains the topographical character of the Tweed.

INDICATIVE SLOPING SITE CHARACTERISTICS AND DESIGN PRINCIPLES

SIDE SLOPING BLOCKS

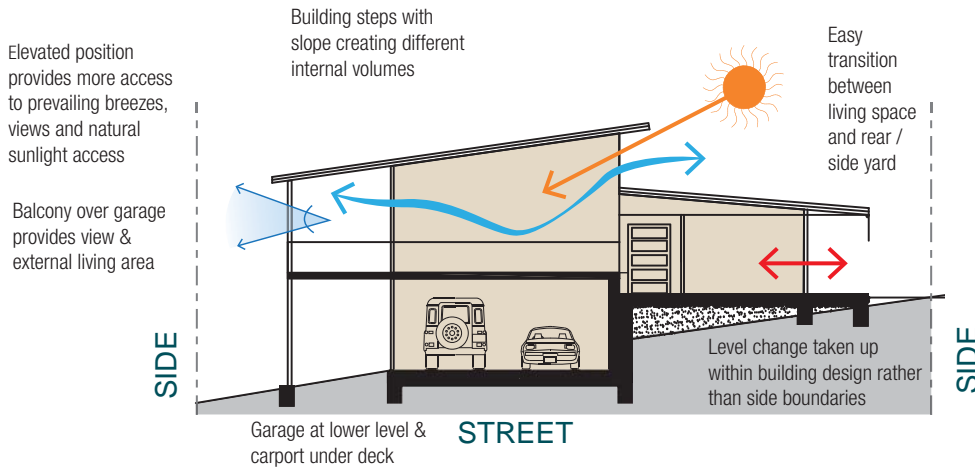

Characteristics

- Site falls across site from side boundary to side boundary.
- Garage doors and driveways generally positioned on lower side of the site.
- Likely to require excavation/fill to accommodate lower level garage.

Design Principles

- Appropriate structural systems includes either split slab with drop edge beam or hybrid lower slab upper level suspended platform.
- Take up level change within the building rather than at the boundary edges.
- Design entrance and living spaces at same level as the street for ease of transition and good universal design reducing pedestrian/vehicle conflict.
- Position garage at lower end with elevated living space of deck over.
- Consider impacts of overlooking and overshadowing on allotments down slope.

DOWN SLOPING BLOCKS

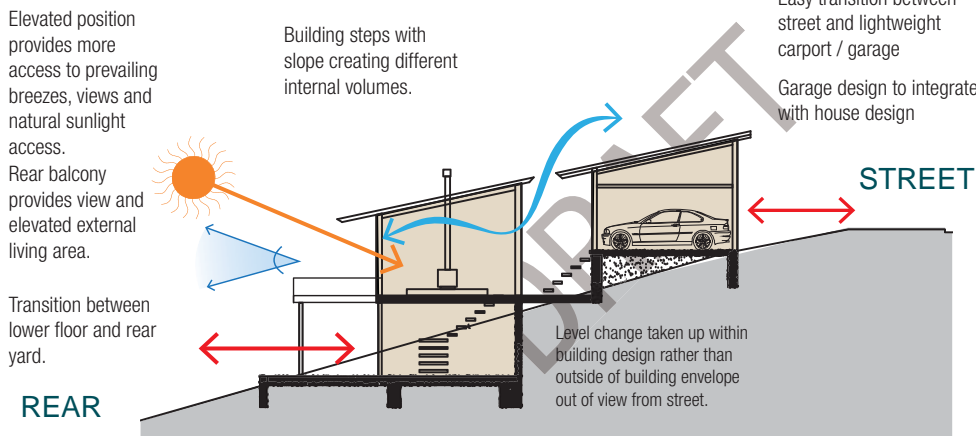

Characteristics

- Site falls from street boundary to rear boundary.
- Garage doors and driveways generally positioned closer to the road edge to avoid steep driveways.
- Likely to have elevated rear deck to take advantage of height, but is disconnected from rear yard.

Design Principles

- Appropriate structural systems includes either split slab with drop edge beam or hybrid lower slab upper level suspended platform.
- Take up level change within the building envelope.
- Design entrance and living spaces at same level as the street for ease of transition and good universal design.
- Detached garages and carports are often appropriate. The overall form and material should be consistent with the house.

UP SLOPING BLOCKS

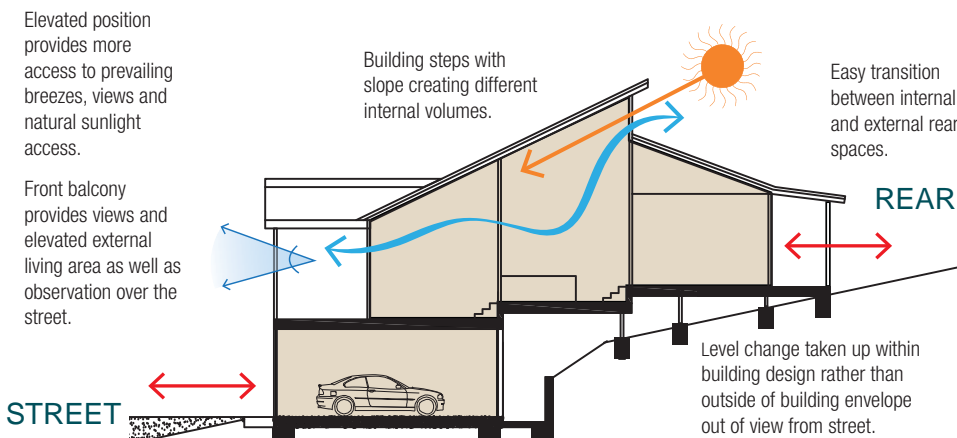

Characteristics

- Site falls from rear boundary to street boundary.
- Generally requires more cut and fill to allow lower level and compliant driveway.
- Garage doors more visually prominent from the street.

Design Principles

- Appropriate structural systems includes either split slab with drop edge beam or hybrid lower slab upper level suspended platform.
- Take up level change within the building envelope.
- Design a balcony to project over garage to reduce visual impact and provide external living space off living areas.
- Consider the design of the undercroft areas which will be visible from the street.
- Avoid full lot width site benching.
- Design levels to achieve easy transition between living spaces and rear yard.

SAMPLE CUT AND FILL DIAGRAMS

Cut and fill on sloping sites is unavoidable. The visual, structural and drainage impacts however can be mitigated by designing the house to step with the landscape and minimise the need for extensive excavation. It is also important to reduce the height of excavation and fill areas which should then be retained where exceeding 1.0m and landscaped to improve the overall visual amenity.

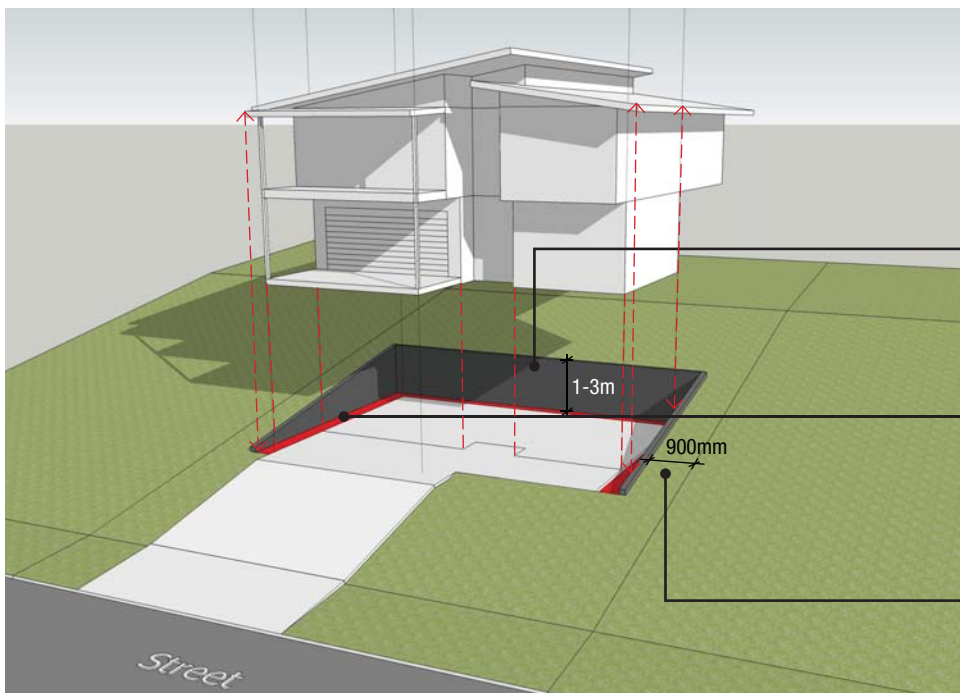
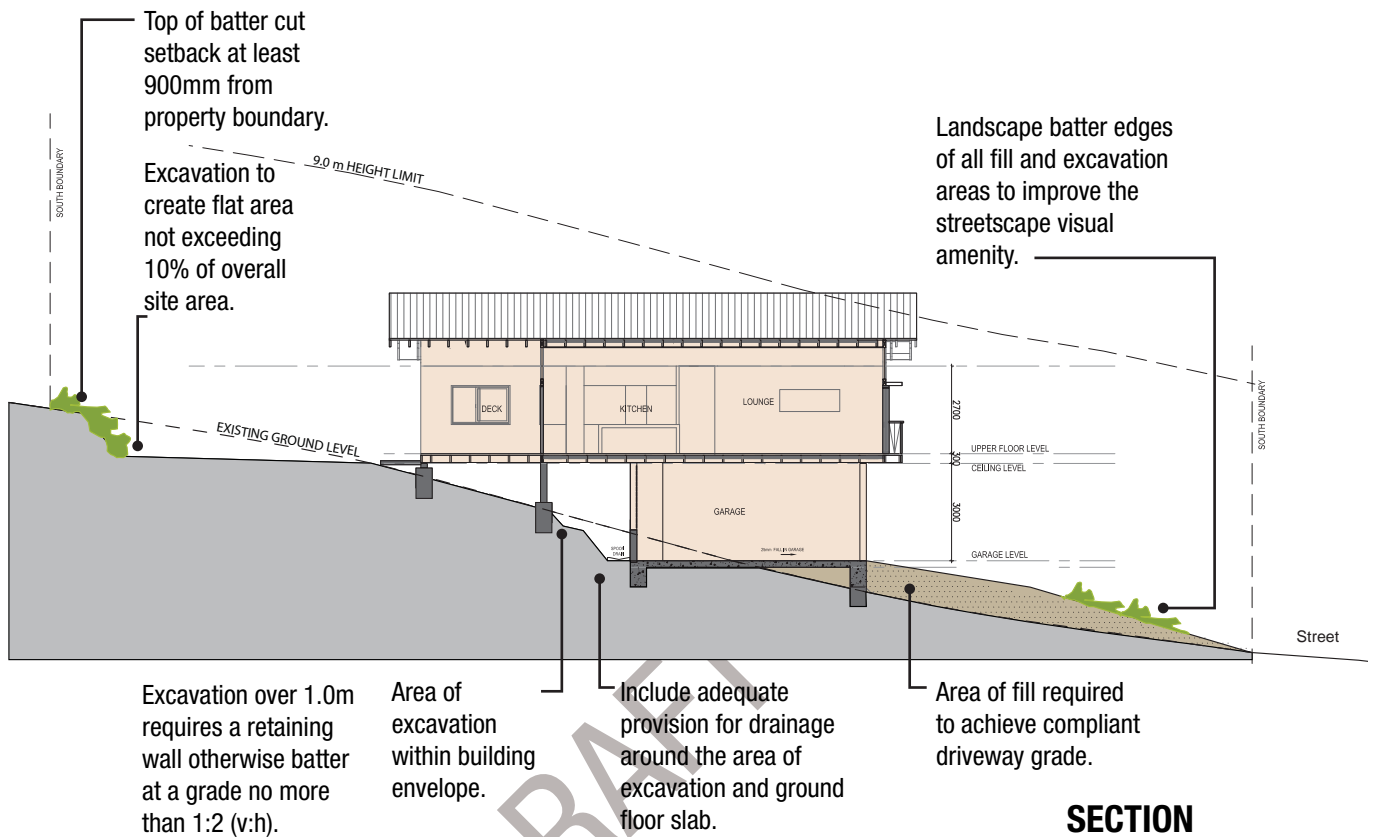

BUILDING FOOTPRINT 3D VIEW

Retaining wall and excavation increases with slope and 'depth of cut' into the site. This amount is controlled within Table 1 Cut and fill Requirements.

Red area denotes the space between the retaining wall and the building wall which is within building footprint defined by outer extent of roofline (gutter). This allows for retaining structure and drainage around the building.

900mm minimum setback to top of batter/retaining wall from property boundary.

2.2. Landscaping, deep soil zones and external living areas

Quality landscaping retains, where possible, significant natural landscape features and mature trees. Greater aesthetic quality and amenity for occupants is achieved when landscaping and buildings are integrated and designed together. As such, landscaping should not be generated by 'left-over spaces' resulting from building siting.

Landscape design builds on the site and the locality's natural and cultural features to contribute to a building's positive relationship to its context and site. Landscape design should optimise function and usability, privacy and social opportunity, respect for neighbours' amenity and the opportunity to interact with the street.

Landscaping also has an important role to play in improving environmental conditions such as storm water and rainwater absorption, habitat for native animals and plants, reducing bushfire risk, and helping to regulate and enhance the amenity of a development through such things as sun shading using pergolas and tree plantings.

Deep Soil Zones

Deep soil zones are areas of natural ground which have a natural soil profile. They are areas free of structures (including underground structures) and hard surfaces. They are suitable for the growth of vegetation, in particular, mature trees, and importantly, they allow water to be absorbed by the soil.

The landscape area has significant environmental benefits including:

- Promoting healthy growth of trees and protecting existing mature trees;
- Retaining the natural hydrological structure of the area;
- Assisting with management of water quality and carbon sequestration;
- Improving the amenity of developments through landscaping that improves micro climatic conditions; and
- Assisting in the creation of vegetation corridors through the locality and wider region.

External Living Areas

External living area refers to a space that extends the internal living and recreation space of a dwelling house to form part of the private outdoor recreational and relaxation space. These spaces generally take the form of courtyards, decks, terraces and balconies, can be paved or decked, and may be covered. **External living areas play an increasing role in the provision of private open space.** External living areas may be located either on ground or above ground. Small balconies and similar structures from bedrooms are not considered external living areas. External living areas are particularly important on steeply sloping sites which don't have ready access to usable backyards.

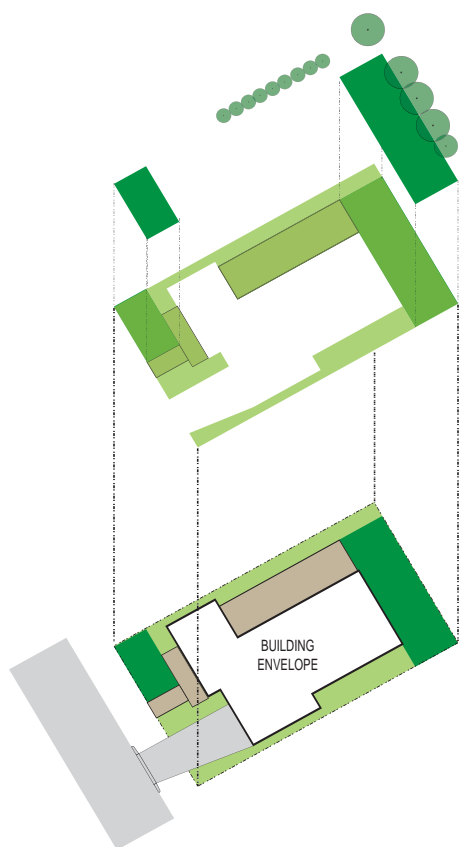

LANDSCAPE AREA comprises the deep soil zone and the balance of other permeable surfaces.

Planning and design principles

Landscaping incorporates the following principles:

- P1. Useful and liveable outdoor spaces are provided by coordinating the design of internal and external living areas, driveways, parking areas, drying and utility areas, swimming pools, landscaped and deep soil areas with the overall site planning and design of the dwelling.
- P2. External living areas are carefully located having regard to achieving and maintaining privacy for the site and neighbours.
- P3. The dwelling and landscaping design is integrated ensuring landscaping and external living spaces optimise the best solar orientation providing shade in summer and solar access in winter.
- P4. Existing important landscape features and mature trees are retained where possible and buildings are not to be sited under the drip line of existing trees.
- P5. A balance of soft landscaping and deep soil areas (for trees plants and water filtration) and lifestyle landscaping (generally hard surface areas such as patios, decks, pools) for leisure activities is achieved.
- P6. Deep soil zones are provided to the rear and to the front of the lot where possible.
- P7. The contribution of landscaping elements to the streetscape is well considered.
- P8. The planting of endemic species integrates residential development with the local environmental context.



SUBURBAN SCALE - Landscaping provides connected flora and fauna corridors through and around blocks.

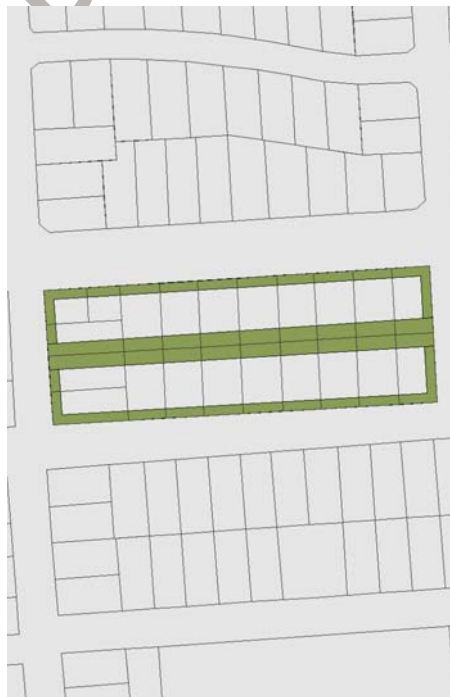

BLOCK SCALE - Contiguous landscaping is traditionally consolidated to the rear and front of lots creating visual buffer

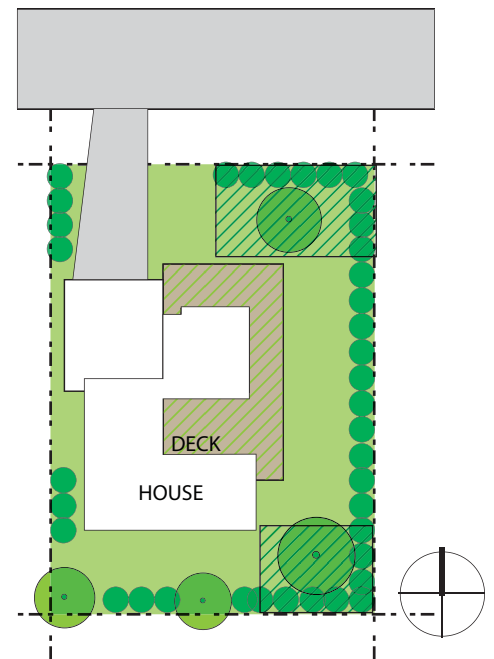

SITE SCALE - Landscape area is the combination of deep soil zone and the balance of other permeable surfaces.

Objectives

01. To enhance the appearance and amenity of development, integrate with the character of the locality and the streetscape and soften the visual impact of urban development.
02. To retain and enhance flora and fauna habitat throughout suburban areas and contribute to flora and fauna corridors.
03. To retain existing important landscape features and mature trees.
04. To provide private outdoor relaxation and recreation space.
05. To enable natural infiltration of rainwater and reduction in stormwater runoff and promote water sensitive urban design.
06. To provide privacy between adjoining dwellings and private open space.
07. To limit heat transfer impacts from hard surface areas, improve micro climatic conditions of sites and the solar performance of dwellings.
08. To contribute to improving urban air quality.

Controls

Landscape

- C1. A lot must include a total landscaped area comprising of the following:

Notes:

Deep soil zone areas are part of the total landscaped area.

Deep soil zone areas can be comprised of one large area or more than one area as long as each meets the minimum dimension requirement.

Landscaping controls	
Lot size	Landscaped area and deep soil zone (Areas less than 1.0m wide can not be included in the calculation)
at least 200m ² but less than 300m ²	15% of the site including at least two deep soil zones measuring a minimum of 2m in any direction
at least 300m ² but less than 450m ²	20% of the site including at least two deep soil zones measuring a minimum of 2.4m in any direction
at least 450m ² but less than 600m ²	30% of the site including at least two deep soil zones measuring a minimum of 3m in any direction
at least 600m ² but less than 900m ²	35% of the site including at least two deep soil zones measuring a minimum of 4m in any direction
at least 900m ² but less than 1500m ²	40% of the site including at least two deep soil zones measuring a minimum of 5m in any direction
more than 1500m ²	45% of the site including at least two deep soil zones measuring a minimum of 6m in any direction
all urban lot sizes	at least 50% of the landscaped area is to be behind the building line of the primary road frontage.
Non-urban (rural land) >1500m ²	No specific requirement

Table 2 - Landscape Requirements

Notes:

Improve the energy and solar efficiency of dwellings and the microclimate of private open spaces through:

- providing deciduous trees for shading low angle sun on the eastern and western sides of a dwelling;
- providing trees that do not cast a shadow over solar collectors at any time of the year;
- providing deciduous trees for shading of windows and open space areas in summer;
- locating evergreen trees away from the building to allow winter sun access;
- varying heights and species of trees and shrubs to shade walls and windows as appropriate;
- locating pergolas on balconies and courtyards to create shaded areas in summer and private areas for outdoor living;
- locating plants appropriately in relation to their size at maturity.
- Designing landscapes to contribute to water and stormwater efficiency by:
 - using plants with low water demand to reduce mains consumption.
 - using plants with low fertilizer requirements;
 - utilising permeable surfaces.

- C2. All new dwelling applications must provide a plan, which may be part of site analysis or on a site plan, identifying landscape area and deep soil locations and a schedule of the landscape area and site coverage calculations.
- C3. A landscape Plan is required for dual occupancy development. A landscape plan may also be requested for dwelling houses where significant earthworks are proposed within the front yard or where a potential streetscape impact has been identified by the assessing officer. The landscaping plan is to include:
- i. Calculations of the landscaped area, deep soil zones and site coverage;
 - ii. Demonstrate how the landscaping complements and integrates with the amenity of the dwelling, the streetscape and any topographical features;
 - iii. Demonstrate how each dwelling achieves integration of the dwelling, landscaped areas, private open space and external living areas;
 - iv. Demonstrate suitable privacy and solar access for each dwelling and its outdoor and landscaped spaces; and
 - v. Detail of plant species to be used and their locations. Species are to comprise no less than 80% native species.
- C4. Existing landscape elements on sites such as natural rock outcrops, watercourses, dune vegetation, indigenous vegetation and mature trees should be retained and integrated with the design of the buildings.
- C5. On lots adjoining indigenous/native vegetation, protect and retain indigenous native vegetation and use native indigenous plant species for a distance of 10m from any lot boundaries adjoining bushland.
- C6. Locate and design landscaping to increase privacy between neighbouring dwellings without excessive shadowing or blocking primary views or existing solar panels.

Deep Soil Zones

- C7. Deep soil zones are to have soft landscaping and cannot be covered by impervious surfaces such as concrete, terraces, outbuildings, swimming pools, tennis courts or other structures or located on structures such as basement car parks or in planter boxes.

Rainwater and Runoff

- C8. Runoff is to be minimised, delayed in its passage and where possible accommodated within the landscape or site surface depressions of the development site unless this is inconsistent with the geotechnical stability of the site or adjacent/downstream land.
- C9. The concentration, collection and piping of runoff to the street gutter or underground stormwater system shall be minimised unless this is inconsistent with the geotechnical stability of the site or adjacent/downstream land.

INDICATIVE LANDSCAPE AND EXTERNAL LIVING LOCATION AND SIZE PLANS



Landscape Plan Whilst a formal landscape plan is not required for most single dwelling development applications, a simplified plan, as required in C2, that shows general landscaping size and location rather than individual species placement will help determine the best positioning of landscape areas in terms relationship to internal rooms, external living areas and for providing shade, privacy and outdoor open space areas.

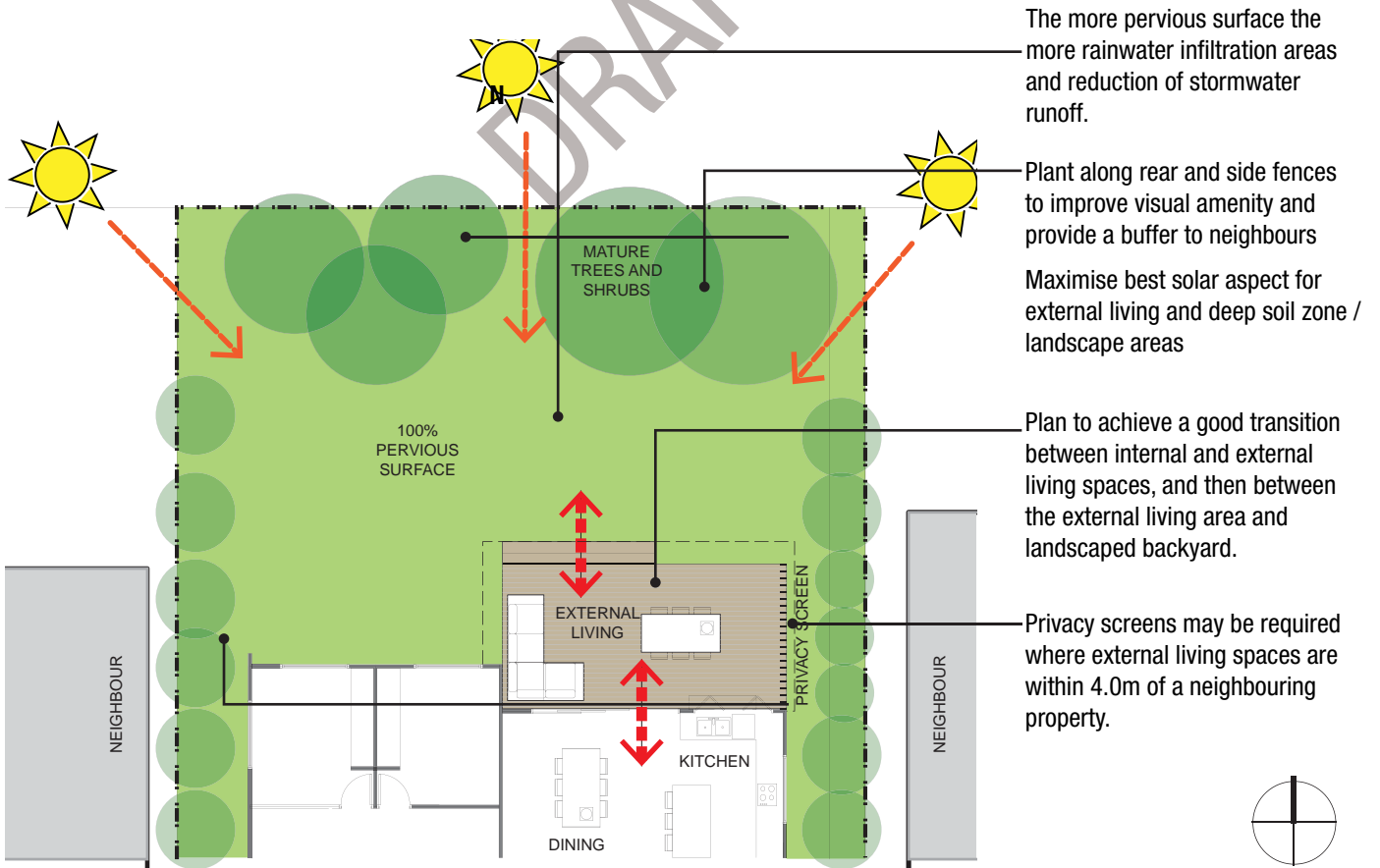

External living areas to the rear of the site provides direct connection between the internal space of the dwelling and the garden or deep soil zone area. Privacy screens may be required to the sides of the space. Ground level external living areas are to be located so as to retain mature trees, mature vegetation and significant landscape features.

INDICATIVE LANDSCAPE ORIENTATION DIAGRAMS

Rear deep soil zone achieves a strong green buffer to rear and side neighbours.

Shade planting to western elevation

Garage and services to western elevation

Achieve level transition with deck and backyard integrating internal with external spaces.

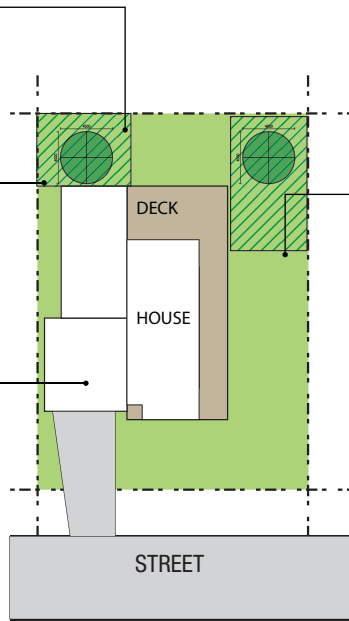

Deep soil zone and external living areas located to take advantage of best northern solar aspect.



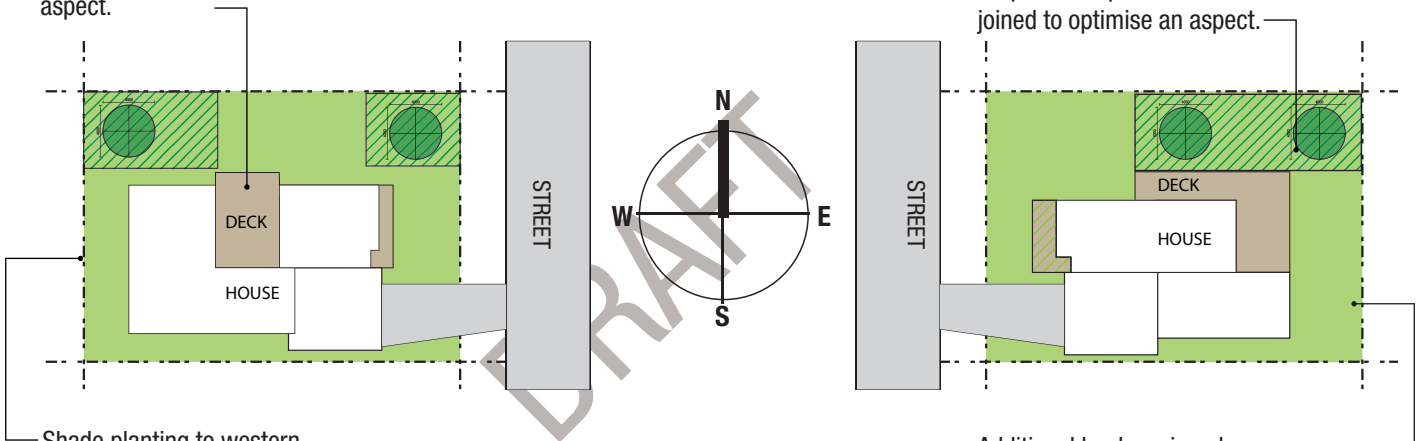

Deep soil zone and outdoor living located to take advantage of best northern solar aspect. Required deep soil areas can be joined to optimise an aspect.



Shade planting to western boundary.

Additional landscaping along rear boundary still achieves landscape buffer to rear neighbour.

KEY

-  MINIMUM DEEP SOIL ZONE DIMENSION
-  LANDSCAPE AREA
-  BEST DEEP SOIL ZONE ORIENTATION
-  EXTERNAL LIVING AREAS

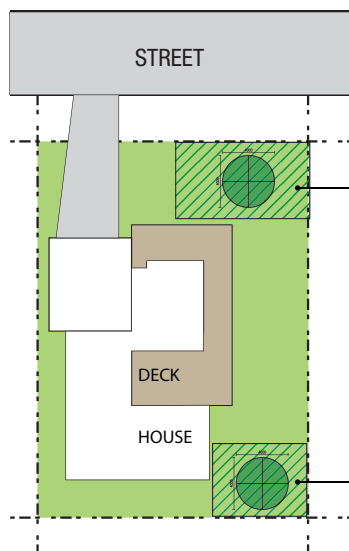

Deep soil zone and outdoor living located to take advantage of best northern solar aspect to the front of the site.

Distribute deepsoil zones across the site to achieve a balanced built form and landscaped outcome.

Inter-allotment planting for shade and landscape buffer.

LANDSCAPE, SITE PLANNING AND ORIENTATION - Examples of integrating the dwelling and open space to enable the best orientation of outdoor living and deep soil zones

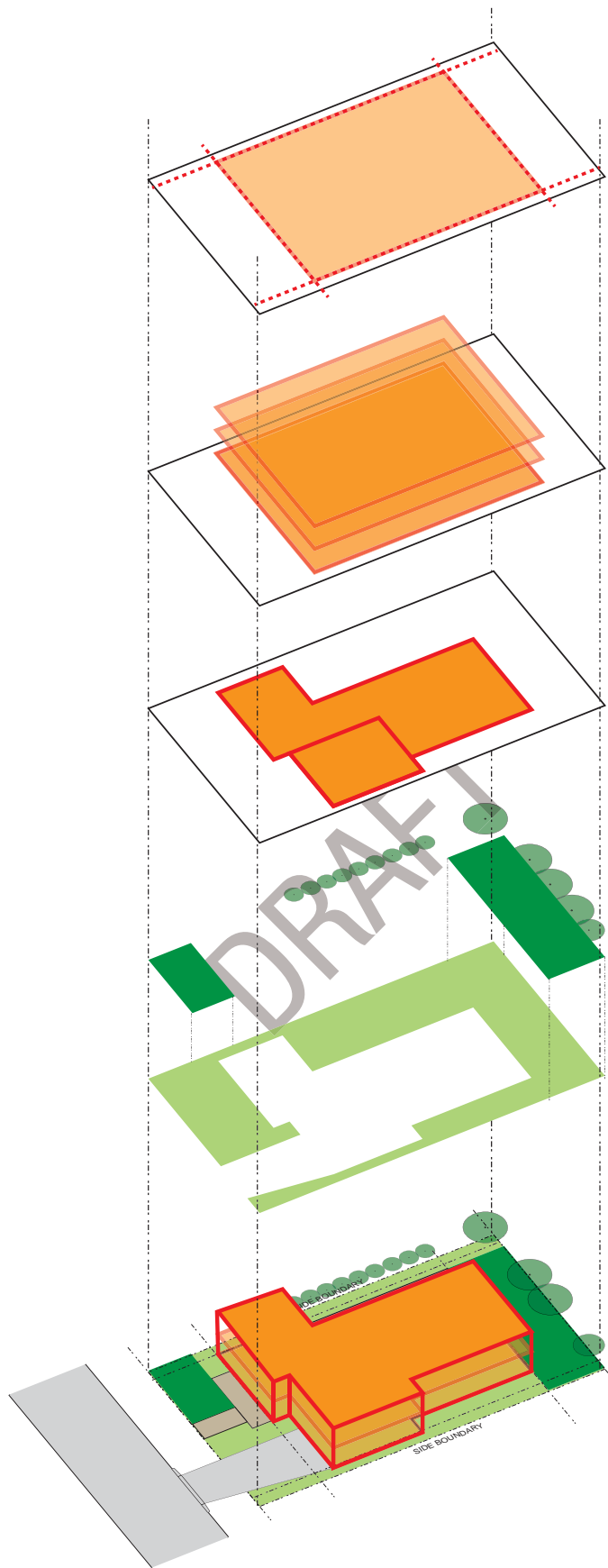

SETBACKS -
Front, rear and side setbacks determined by lot size and building height.

BUILDING HEIGHT -
Allowable building height measured from existing ground level.

SITE COVERAGE -
Total area of the site that can be covered by the building and ancillary development as a percentage of the lot size.

LANDSCAPE AREA - Total area of the site consisting of permeable surfaces and deep soil zones.

SITE PLANNING AND BUILDING FORM -
A response to site opportunities and constraints and building envelope requirements.

Building envelope and landscape controls - Building envelope and landscape controls work together towards achieving a balanced site outcome. As such building envelope and landscape controls should be read and applied in conjunction rather than in isolation of each other.

3. Building envelope controls

A building envelope is not a building, but a three dimensional space within which the building may be constructed. The building envelope defines the maximum boundaries or space of the development, however, this does not imply that a building may 'fill' the entire envelope.

The key criteria that help define the building envelope include:

- Setbacks;
- Height; and
- Site coverage.

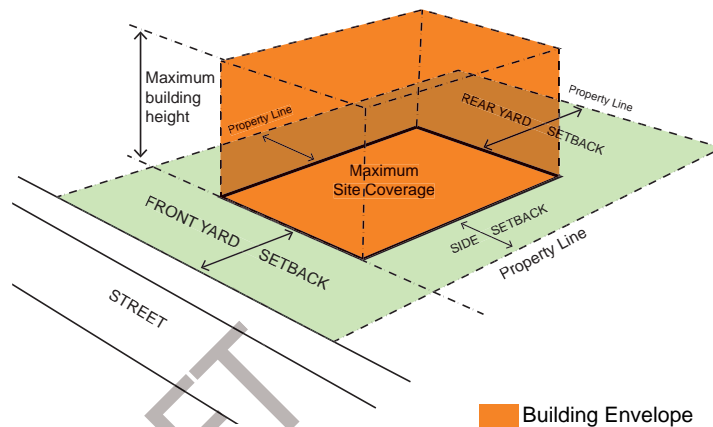

3.1. Setbacks

Setbacks are important as they establish the buildings location in relationship to the lot boundaries, the street and neighbouring buildings. Setbacks allow space for landscaping, retention of views, access to breezes, solar access and facilitate privacy and adequate separation between dwellings in residential areas.

The setback from the front boundary establishes the location and alignment of the buildings front elevation. Front setbacks help create the proportions of the street and contribute to the public domain by unifying streetscape character and the continuity of street elevations. Street setbacks enhance the setting for the building as they provide for landscape areas and entry to the dwelling.

Rear setbacks are important for achieving open space to the rear of the lot to allow for landscaping and deep soil areas, water infiltration as well as providing private areas for external living, recreation and relaxation.

Side setbacks are important for achieving building separation enabling sunlight access whilst avoiding overlooking and overshadowing.

In some areas the residential character may be of smaller lots in a more urban form. These areas may use zero-lot boundaries to create a particular style and allow the dwelling to respond to the best orientation.

Canal frontages are considered as the rear boundary to the allotment.

Planning and design principles

Setbacks incorporate the following key principles:

- P1. Front setbacks respond to topographic or sloping conditions, frame the street and include articulation to a buildings front elevation.
- P2. Rear setbacks incorporated as an area of private open space contribute to the rear lot landscape pattern.
- P3. Side setbacks respond to site orientation, sunlight sharing with neighbours, potential overlooking and privacy impact.

Objectives

- O1. To establish the desired spatial framing of the street, define the street edge and enable a transition between public and private space.
- O2. To provide flexibility for steeply sloping and corner allotments to best address streetscape, solar orientation and location for outdoor amenity areas and access points.
- O3. To provide appropriate separation between dwellings for sunlight access, ventilation, visual and acoustic privacy and access to the rear of the allotment.
- O4. To minimise overlooking and overshadowing to the site and of adjoining allotments.
- O5. To facilitate a landscape setting for residential buildings and retention of the rear yard landscape zone.
- O6. To maintain views and vistas along canal foreshores.

Controls

Front and rear setbacks

- C1. The minimum setback from the street and rear boundary for a dwelling is:

Lot size	Minimum front setback - New Areas (for established and existing areas refer C2 below)	Minimum front setback to secondary street frontage on corner allotments	Minimum rear setback where the building is up to 4.5 metres in height	Minimum rear setback where the building is 4.5 metres in height or greater
less than 300m ²	3.5 metres	2 metres	3 metres	4.5 metres
at least 300m ² and less than 600m ²	4.5 metres	2 metres	4.5 metres	6 metres
at least 600m ² and less than 900m ²	6.0 metres	3 metres	4.5 metres	8 metres
at least 900m ² and less than 1500m ²	6.0 metres	3 metres	5 metres	12 metres
at least 1500m ²	8.0 metres	5 metres	10 metres	15 metres

Table 3 - Front and Rear Setbacks

Setback calculations

The front setback is measured from the front boundary of the allotment to the outer most edge of the wall of the building elevation.

Rear setbacks are measured from the rear boundary to the outside edge of the building wall.

Setbacks are measured at 90 degrees to the allotment boundary and include any articulation to the building elevation but do not include external living.

Side setbacks are measured from the allotment's side boundary to the outside edge of a building wall.

- C2. In established areas and on infill sites dwelling houses are to be consistent with the front setback distance of neighbouring buildings and are to be the average of the setbacks of neighbouring dwellings within 40 metres or a variation justified under a streetscape analysis. This setback may be varied up to 1 metre where justified through a streetscape analysis.
- C3. An articulation zone may permit some elements of a buildings front facade to intrude within the front setback to a maximum of 1.5 metres and not exceeding 25% of the frontage width. The following building elements may be permitted in an articulation zone:
- i. an entry feature or portico;
 - ii. a balcony, deck, patio, pergola, terrace or verandah;
 - iii. an upper level overhang or cantilever;
 - iv. a window box treatment;
 - v. a bay window or similar feature;
 - vi. an awning or other feature over a window; and
 - vii. a sun shading feature.
- C4. The minimum front setback for a garage perpendicular to a primary or secondary street frontage is 5.5 metres to allow off-street parking that does not impede the footpath.
- C5. Garages and carports, including semi-basement garages and attached garages, are to be set back a minimum of 1 metre from the dwelling's front façade, unless it can be demonstrated how the design mitigates the dominance of the garage door to the street elevation (refer to indicative diagrams on page 47).
- C6. Council may approve the erection of a garage which does not comply with the required front building line setback where exceptional circumstances, such as the depth and shape of the allotment, slope or grade, make it necessary and as supported by a site analysis that demonstrates:
- i. no other suitable location is available behind the building line;
 - ii. there is no vehicular access to the rear or side of the allotment;
 - iii. the proposal will not affect the amenity of adjoining properties;
 - iv. the design of the garage is complimentary to the design, materials and roof form of the dwelling;
 - v. the proposal will not create an unwanted precedent to the vicinity;
 - vi. the proposal does not result in the creation of additional driveway access;

- vii. the proposal will not impede on the required pedestrian and traffic sight lines;
 - viii. there are no valid objections are received from adjoining property owners;
 - ix. the structure is located a minimum of 900mm from the side boundary of the property.
- C7. A carport may be permitted to encroach within the front setback subject to the following criteria:
- i. No other suitable location is available behind the building line;
 - ii. It is located a minimum of 900mm from the side boundary;
 - iii. Does not exceed 33% of the width of the allotment frontage or 6 metres measured between supporting posts whichever is the lesser;
 - iv. It is of an open design with two or more sides fully open;
 - v. Frontage facing the street is to remain open and shall not be fitted with a door or enclosing device of any kind;
 - vi. Posts or columns do not obstruct vehicle manoeuvrability or visibility;
 - vii. The roof design is to complement the roofline of the existing house and not significantly impact the streetscape; and
 - viii. The roof is not trafficable.
- C8. Garages, outbuildings and carports may be located a minimum of 450mm from the rear boundary where no greater than 4.5 metres in height.
- C9. Garages and carports accessed by a rear laneway are to be setback a minimum of 1.0m from the laneway.
- C10. Secondary dwellings require a minimum **setback from the rear boundary of 1.5m** where single storey and **3 metres** where two storey.

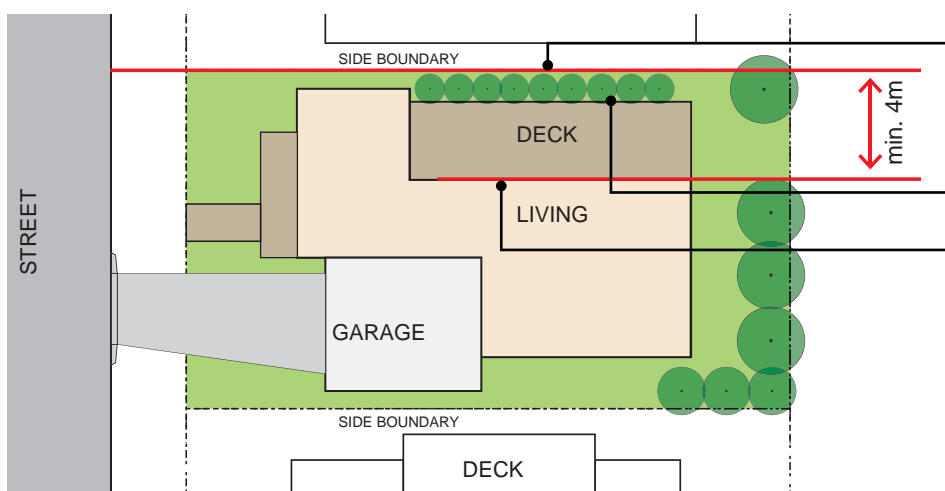

Design high level glazing (obscured glass) to north neighbours southern elevation to reduce overlooking impacts.

Screen planting for privacy and visual amenity.

4.0m setback to internal principle living spaces to enable northern sunlight access, increase building separation and privacy.

Living room doors facing side boundary setback 4.0m to ensure adequate natural light access and privacy from neighbouring dwellings.

Living Area Setback 4.0m - On east-west allotments, the long side boundary is orientated to the north. The setbacks and external living areas are required to ensure sunlight sharing and mitigation of overlooking and privacy impacts.



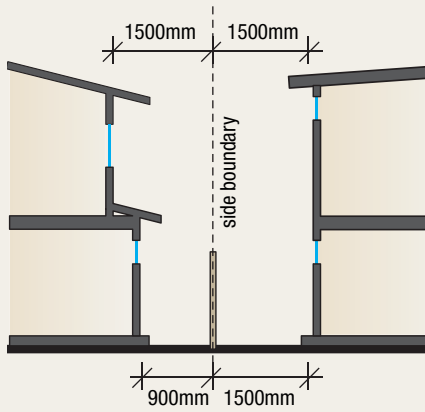

Indicative side setback diagram.

Note:

Refer to Garage Configuration diagrams on page 45 which identifies some design mitigation measures to reduce the garage door dominance to street elevations.

Design Control 4.7 - Garages, Driveways and Car Parking also contains provisions relating to setback to garages and carports and should be read in conjunction with these controls.

Design Control 6.2 - Outbuildings also contains provisions relating to setbacks and should be read in conjunction with these controls.

C11. **Roofed** external living areas are to be setback a minimum of 3.0m from the rear boundary.

Side setbacks

- C12.** A single storey dwelling, or that part of a building containing only single storey, is to be setback a minimum of 900mm from the side boundary line to the wall of the building. Guttering, eaves, hoods and other similar structures may be constructed within the side setback but not closer than **450mm** from the boundary.
- C13.** A two storey dwelling, or the second storey component of building, is to be setback a minimum of 1.5m from the side boundary line to the wall of the building. Guttering, eaves, hoods and other similar structures may be constructed within the side setback but not closer than **900mm** from the boundary.
- C14.** On corner allotments primary and secondary streets are to be clearly nominated and comply with the appropriate primary and secondary street setbacks.
- C15.** On corner allotments are to nominate location of side and rear setbacks and comply with the appropriate setbacks.
- C16.** Garages, whether attached or detached, may be located a minimum of 450mm from a side boundary except where located within the front building setback.
- C17.** Carports may be located adjacent to a side boundary, except where located within the front building setback, subject to:
 - i. the boundary wall remaining open;
 - ii. the carport support is not attached to a fence; and
 - iii. the proposed carport complies with the Building Code of Australia.
- C18.** Where **opening doors** of living rooms face the side boundaries the living room is to be setback a minimum of 4m from the side boundary. This setback may be required to be appropriately screened to minimise overlooking and privacy impacts.
- C19.** External living areas adjoining side boundaries are to be setback a minimum of 900mm from the side boundary. **This external living area may be required to be appropriately screened and/or the setback increased where there may be overlooking and/or privacy impacts.**
- C20.** Where rainwater tanks, water heaters, air conditioning units, retaining walls and the like are located within a side passage, walkable access to and around these items is to be maintained.

Canal frontages

C21. The setback from a canal frontage is:

- i. 5.5m where the boundary is on the canal side of a revetment wall, or
- ii. 3.4m from the revetment wall where the wall is on the boundary, except:
 - for those lots with canal frontages and facing Gollan Drive and Jacaranda Avenue, Tweed Heads West where the setback line to the canal frontage shall be 2.5m; and
 - Lots 1, 2, 3 and 4 Crystal Waters Drive, Tweed Heads West where normal building setbacks shall apply along the canal frontage.

C22. No structures are to be built within the setback area other than fences to 1.2 metres high, swimming pools, retaining walls, suspended decks that do not exceed the level of the allotment at the top of the batter and boat ramps except:

- i. For those allotments with canal frontages and facing Gollan Drive and Jacaranda Avenue, Tweed Heads West where the setback line to the canal frontage shall be 2.5m; and
- ii. Lots 1, 2 3 and 4 Crystal Waters Drive, Tweed Heads West where normal building setbacks shall apply along the canal frontage.

C23. The underside of any suspended deck fronting a canal is to be suitably screened, except in cases where giving effect to this control would result in adverse impact to flood waters.

INDICATIVE SETBACK DIAGRAMS - SINGLE DWELLINGS

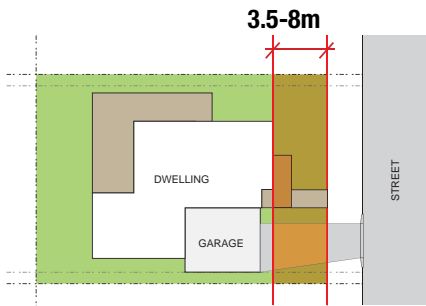

Front building setback 3.5-8.0m

Refer Control 1, Table 3.

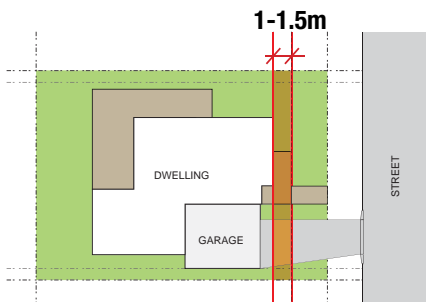

Articulation Zone 1-1.5m

Allowed within the front setback of new dwelling where the intrusion does not exceed 25% of the frontage width. Refer Control C3.

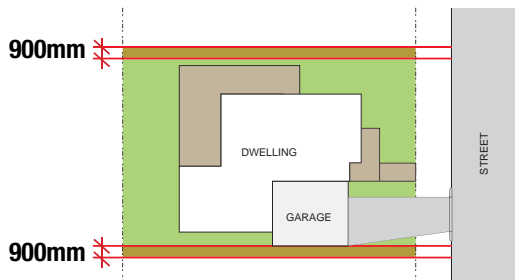

Side setback single storey 900mm.

Refer Controls C12.

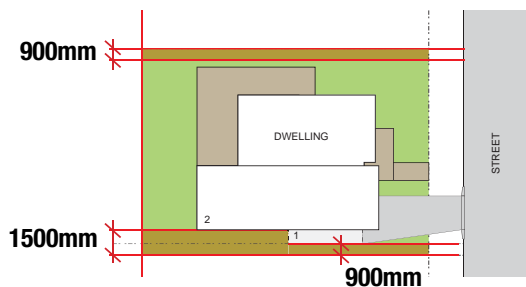

Side setback double storey 1500mm

900mm for single storey component. Refer Controls C13.

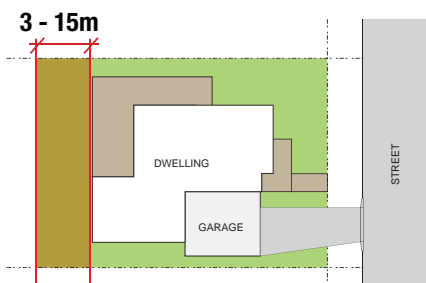

Rear setback 3-15m

Depending on building height and lot size. Refer Control 1, Table 3

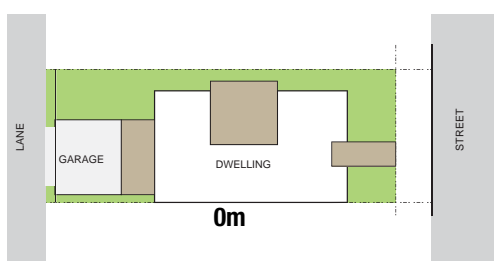

Zero setback

Along one boundary where the allotments form part of a zero lot / terrace / row / courtyard integrated housing development.

SAMPLE CORNER SITE SETBACKS

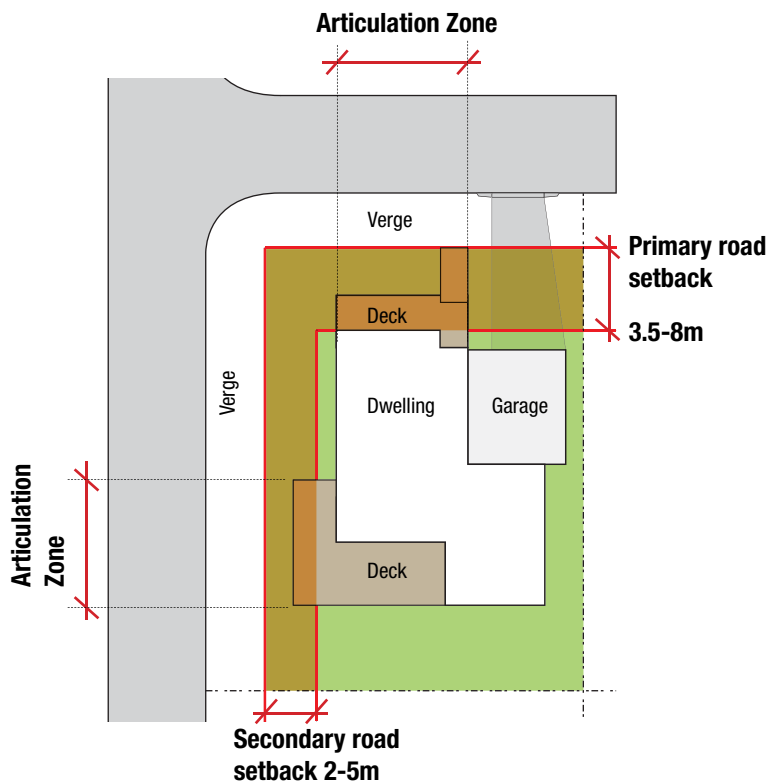

SAMPLE DUAL OCCUPANCY SETBACKS

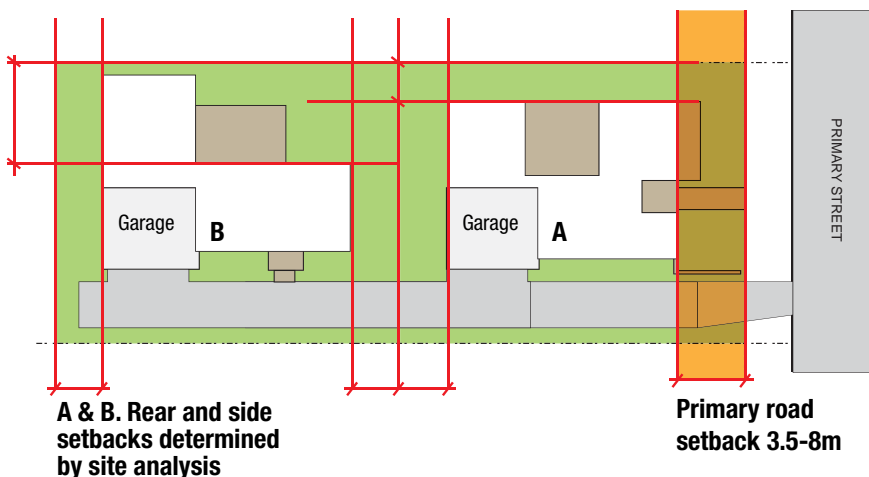
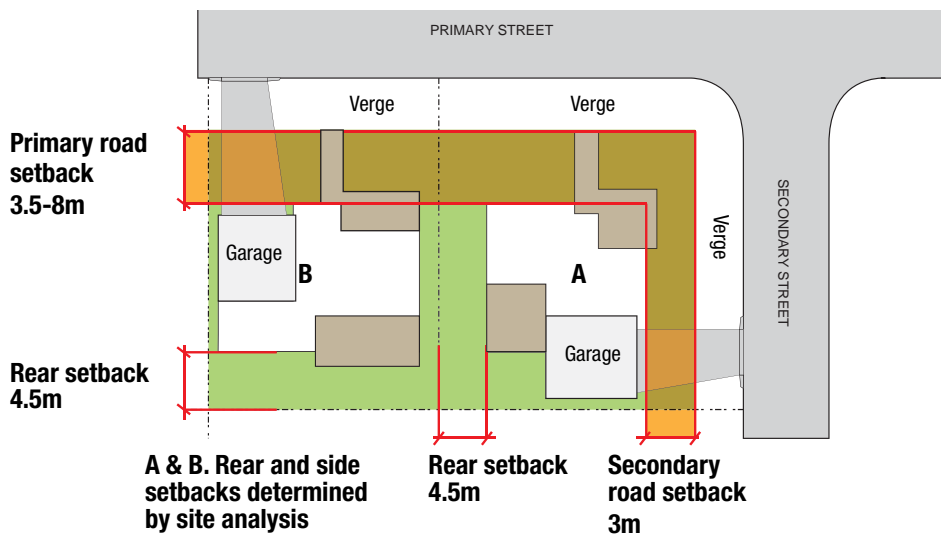

Corner Allotments Setbacks

A corner lot has a minimum setback to both road frontages. The setback distance varies dependent on the lot area and nominated primary and secondary street frontages. Consider the following principles:

- site analysis to determine best site configuration;
- nominate primary and secondary frontage based on site analysis outcomes;
- nominate side and rear boundaries for the purposes of allocating setbacks;
- design dwelling(s) to address both frontages;
- provide 'rear setback' to at least one nominated boundary,
- consider safety and site lines for locating driveway car parking access.
- sensitive integrated fence design and landscape to improve streetscape.

Corner Dual Occupancy Setbacks

As per detached dwellings on corner allotments applicants are to nominate primary and secondary street frontages based on a site analysis to determine front and secondary street setbacks.

Similarly applicants are to nominate side and rear setbacks based on a site analysis that considers best solar orientation, deep soil location and relationship to habitable internal spaces.

Stacked Dual Occupancy Setbacks

A stacked dual occupancy has one street frontage which can be applied to dwelling A, however the 'front', rear and side setbacks as they would apply to dwelling B need to be determined by a site analysis to determine best site configuration. This is largely influenced by whether the dwellings are attached or detached and solar orientation.

SAMPLE OPTIONS FOR MINIMISING THE DOMINANCE OF GARAGES

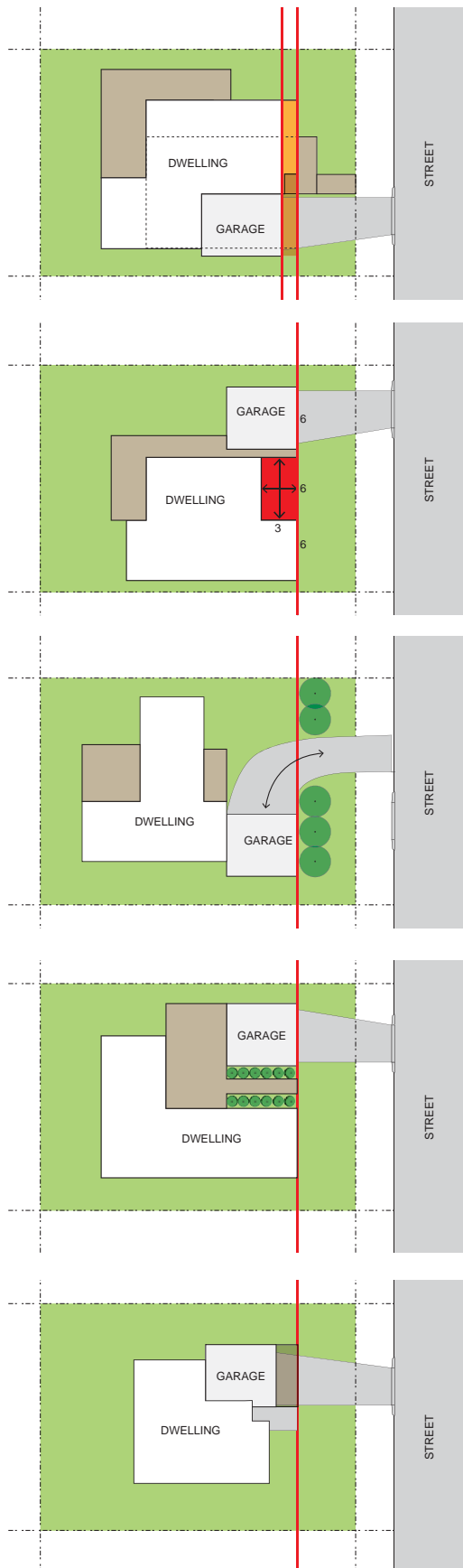

1. Garage Setback 1.0m behind front building line - This allows the principle building and lightweight structures within articulation zone to be forward and therefore more visually dominant to the street.

2. Stepping Building Line - An alignment of garage and principle can be achieved where there is a demonstrated step of depth to a building's elevation. This also allows an area of more substantial front yard landscaping. The step needs to be proportional to the width of the garage.

3. Garage Rotated 90 degrees - By rotating the garage and articulating the garage street elevation with windows behind a landscape setback reduces the dominance of the double garage door. Garage elevation to the street can then be appropriately articulated and landscaped.

4. Strong architectural element - Often the design of the garage in alignment with the principle building is acceptable with a consistency of materials, and roof pitches that complement the overall architectural intent of the building.

5. Garage below projecting deck - Particularly on upslope sites, an upper level projecting deck with garage recessed below on the lower level significantly reduces the visual impact of the garage.

Garage Setback Options - The intent of garage design principles, objectives and controls is to reduce the visual dominance of the double garage door on the streetscape. The above diagrams illustrate some measures to reduce the garage door visual dominance.

3.2. Building height

Building height controls allow management of the bulk and scale of development and to assist in integrating new development into existing areas. This is important in scenically significant areas and in the context of the rapidly increasing residential development in both coastal and hinterland areas where the protection of existing levels of character and amenity is both important and difficult.

Planning and design principles

Building height will incorporate the following key principles:

- P1. Is compatible with the character of the surrounding residential development;
- P2. Establishes a relationship between site works (cut and fill), building design and outdoor area access;
- P3. Follows the rhythm of the existing topography;
- P4. Enables flexibility of height and roof design on steep sites;
- P5. Responds to potential overshadowing impacts on neighbouring properties;
- P6. Avoids large unbroken elevations and vary roof planes and roof pitches to reduce the overall building bulk; and
- P7. Enables design compatible with the Tweed climatic context.

Objectives

Note:

The definitions of 'building height' and 'storey' are included in the Local Environmental Plan (LEP).

- O1. To ensure the height of buildings is appropriate to the residential scale and character of the street and the local area.
- O2. To ensure dwellings are sensitively designed to minimise impacts on privacy, solar access and views to or from the dwelling or the adjoining dwellings.

Note:

Design Control 4.7 - Garages, Driveways and Car Parking also contains provisions relating to heights and should be read in conjunction with these controls.

Building heights are a development standard within the LEP and variations must be accompanied by appropriate justification in accordance with the LEP - Section 4.6.

Controls

- C1. The overall building height is 9 metres, except on slopes of greater than 12 degrees (21.25%) where the building height may be a maximum of 10 metres.
- C2. The maximum height for a carport and detached garage is 3.5 metres where there is a flat roof or 4.8 metres where there is a pitched or skillion roof.

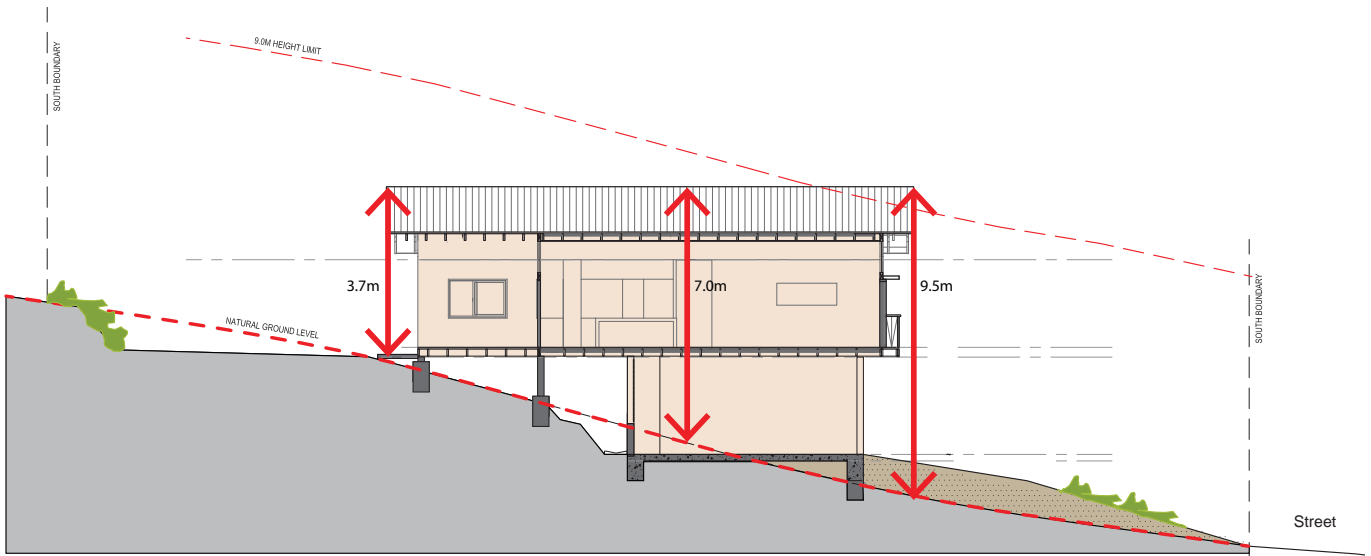

Building Height Measurement - Building height is the height of a building at any point of a building and is the vertical distance between the existing ground level and the highest point of the building.

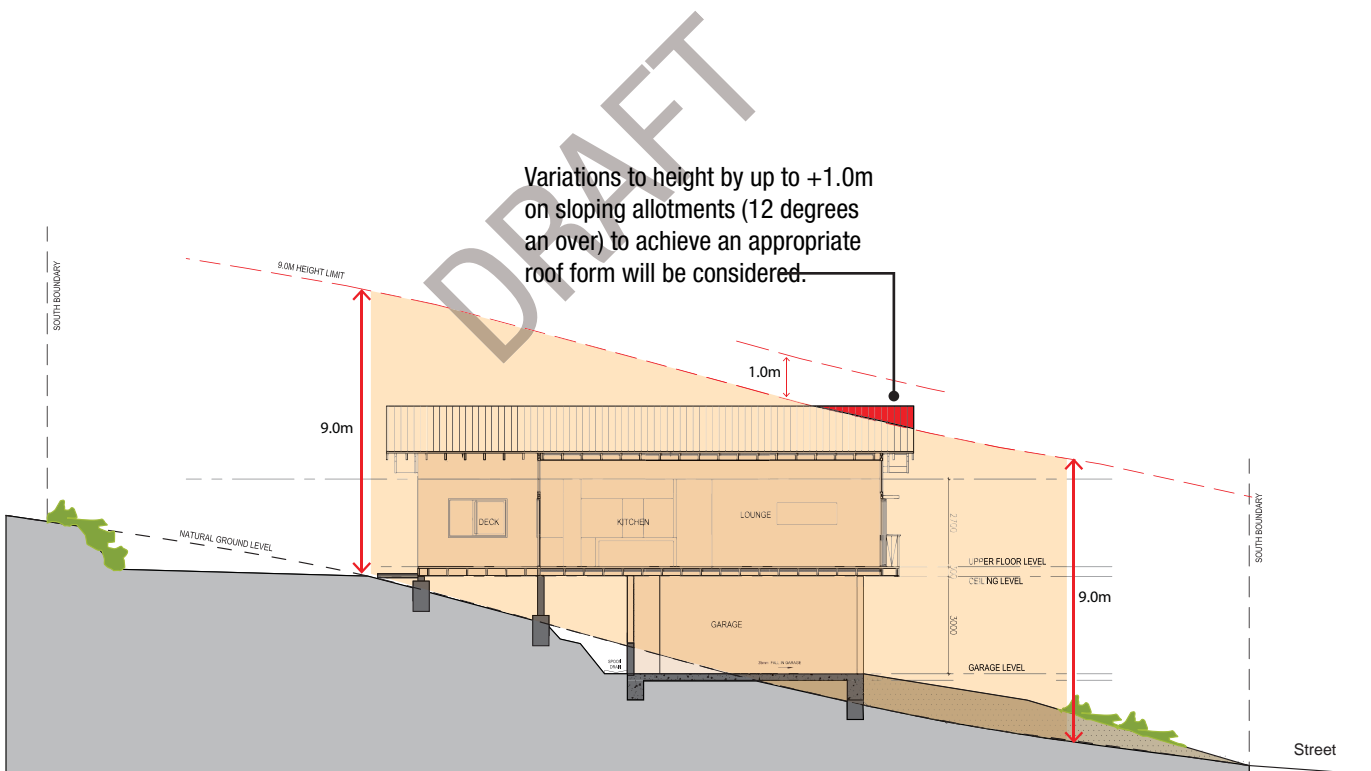

Variations to height by up to +1.0m on sloping allotments (12 degrees or over) to achieve an appropriate roof form will be considered.

Building Height on Sloping Blocks - Provision of an additional 1.0m on allotments with slopes over 12 degrees recognises the challenges of achieving a 2 storey dwelling with an appropriate roof form on steeply sloping sites. The extent of the variation needs to be clearly identified as part of a submitted section/site analysis along with shadow diagrams to demonstrate adjoining amenity will not be significantly compromised in terms of overshadowing and overlooking. Height concessions for the express reason of achieving an additional storey will generally not be supported.

DRAFT

3.3. Site coverage

Site coverage is the two dimensional footprint a building may occupy. It is essentially a percentage of the site that may be built upon.

Site coverage may be further defined as impermeable and permeable. Excessive site coverage with hard surfaces can increase the volume of stormwater discharged off-site as it reduces the land's capability to infiltrate water in storm events.

Planning and design principles

- P1. Use the site analysis process to determine the appropriate balance of internal, external and landscape areas.
- P2. Promote on-site stormwater infiltration by encouraging pervious surfaces and landscaped areas.

Objectives

- O1. To ensure a balance of built form and landscaped area.
- O2. To ensure residential development is sympathetic with the existing topography, water cycle and amenity of the site and neighbourhood.

As a guide the calculation of site coverage generally does not include access ramps, awnings, eaves, unenclosed balconies, decks, pergolas, terraces, verandahs, driveways, paths, swimming pools and spas. Refer to site coverage definition within the LEP.

Secondary dwellings are considered as part of the main dwelling house for the purpose of site coverage calculations.

Controls

- C1. The maximum site coverage of a dwelling and all ancillary development on a lot must be consistent with the following:

Allotment size	Maximum site coverage
at least 200m ² but less than 250m ²	65%
at least 250m ² but less than 300m ²	60%
at least 300m ² but less than 450m ²	55%
at least 450m ² but less than 900m ²	50%
at least 900m ² but less than 1500m ²	40%
greater than 1500m ²	30%

Table 4 - Site Coverage

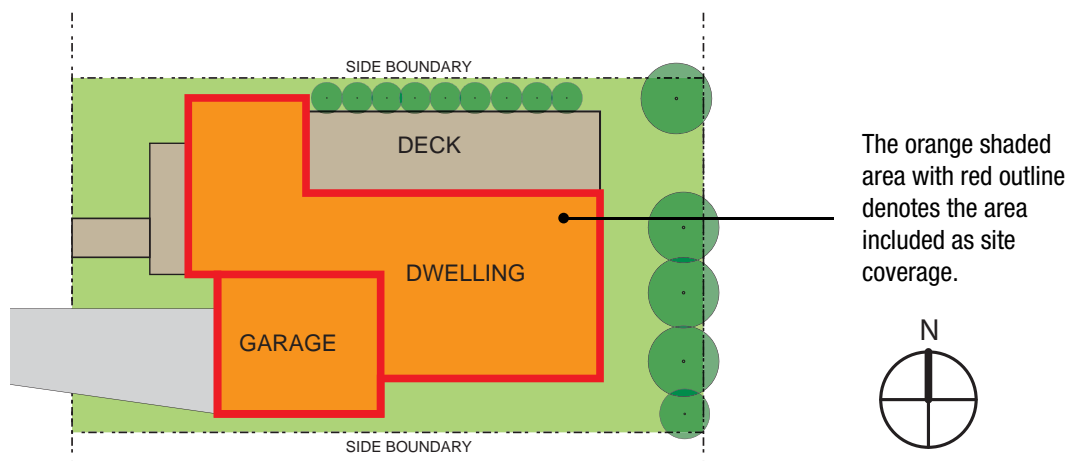

CLIMATE AND ORIENTATION

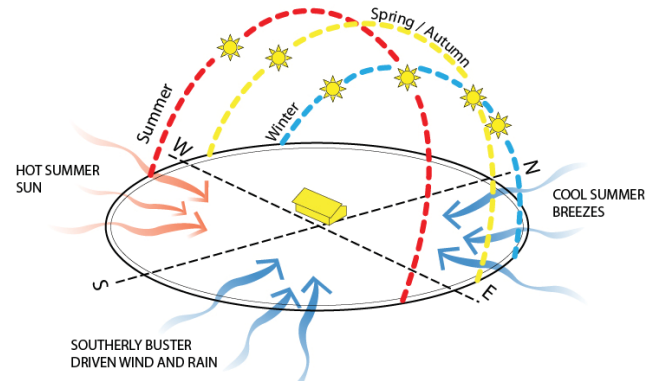
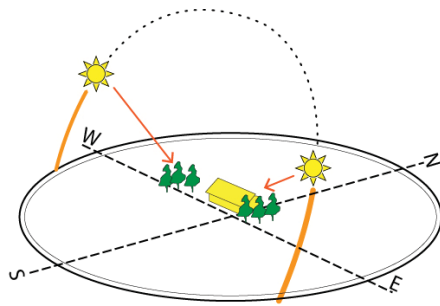

Solar Access and Orientation - Northern orientation is the best for the Tweeds climatic zone. From sunrise to 9am and from 3pm to sunset the sun is lower in the sky. House design should acknowledge potential high heat loads from the south east during summer mornings and south west during summer afternoons.

THERMAL MASS AND SHADING

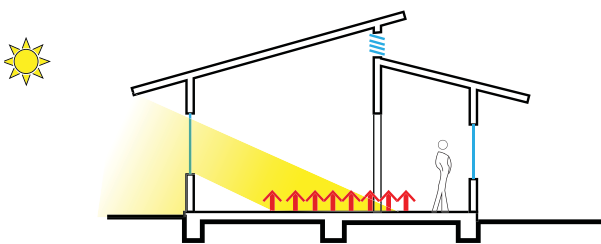

In winter - solar access should be maximised to improve heat gain from the lower northerly sun path. Floors and walls made of mass material will store heat during the day which will be released at night to warm the house.

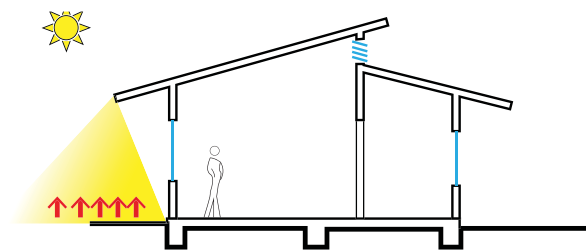

In summer - protect your home from heat gain from low angle sunlight on the eastern and western walls by designing deep eaves, vertical shading, screens or blinds and integrating landscape and shade trees.

INSULATION

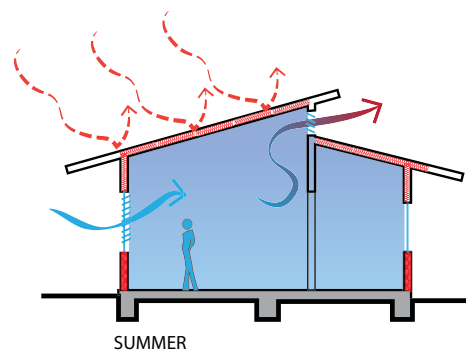
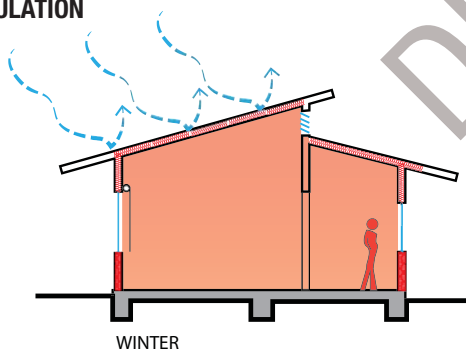

Insulation - Wall, floor and roof insulation enables a more stable internal temperature both during the summer (keeping heat out) and winter (keeping heat in).

CROSS VENTILATION

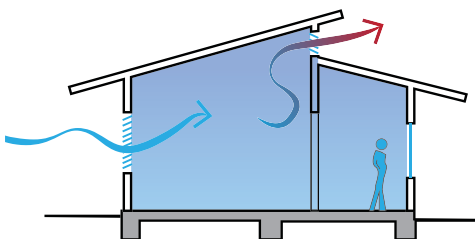

Ventilation - Higher level windows or ceiling cavity will create stack ventilation which allows hot air to continually escape and be replaced by cooler air.

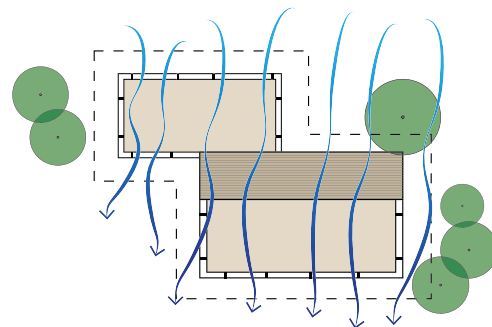

Building Shape and Orientation - Narrow spaces promote better air circulation, maximise northern exposure and offer the best possibilities for moderating the homes internal climate.

4. Building design

Well considered building design in response to a site analysis has the potential to greatly enhance building amenity. Building amenity refers to the way in which the building provides a high quality of livability for residents. Amenity is derived through the ability of spaces to adequately provide for their intended function and level of activity. This is facilitated by rooms of suitable dimensions and flexible layouts. The key aspects of building design and amenity include; designing for climate, building orientation and separation, sunlight access, visual privacy, acoustic privacy, view sharing, and natural ventilation.

4.1. Designing for the Tweed climate

The Tweed is located within a sub-tropical climate zone. The main characteristics of a sub-tropical climate zone are:

- Highly humid with a degree of dry season;
- High temperatures year round;
- Minimal seasonal temperature variation; and
- The lowest diurnal (day/night) temperature range.

The use of passive solar design in dwellings is encouraged. With the Tweed's temperate sub-tropical climate, well designed houses in Tweed should only require a limited amount of heating and cooling. The heat load resulting from direct solar penetration into buildings during the hotter months can be a problem, and so it is important that dwellings are designed to optimise the benefits of sunlight, whilst minimising its negative effects.

The orientation of the allotment, the immediate subdivision pattern and the local topography, have a significant impact on the ability to provide appropriate solar access. Sites on the southern side of a hill, for example, may not receive the same level of sunlight access those on the northern side. On allotments where the side boundary has a northerly aspect, consideration should be given to increasing the side setback to improve sunlight access. Similarly, reducing the bulk and height on the southern boundary may reduce overshadowing of northern sun to adjoining properties.

Ideally, solar access should be maximised in winter and minimised in summer. A northerly aspect is most desirable as it provides the most solar access in winter and is relatively easy to shade in summer. A south-westerly aspect is least desirable, particularly in summer where the lower angle of the setting sun can add significant heat load to a dwelling. Protection for a westerly aspect can be achieved by using such elements as deep eaves, vertical sun shading devices, window tinting, blinds and landscape.

Daylight consists of both diffused light and direct light. Good levels of daylight in a dwelling improve amenity and reduce the need for artificial lighting. Good levels of daylight can be achieved through the careful consideration of window size, location and proportion.

Natural ventilation is the circulation of sufficient volumes of fresh air through dwellings to create a comfortable indoor environment. Designing for natural ventilation incorporates sustainable design practice by responding to the local climate, captures cooling summer breezes, and reduces or eliminates the need for mechanical ventilation.

Dwellings which are designed appropriate to the subtropical climatic conditions are less expensive to run, generally reduce the household's 'carbon footprint' and have a greater level of living amenity.

4.2. Passive design

Passive design is a term used to describe design which takes advantage of the natural climate to maintain thermal comfort.

Incorporating the principles of passive design:

- significantly improves internal and external levels of comfort;
- reduces reliance and therefore cost of mechanical heating and cooling, and
- reduces greenhouse gas emissions associated with heating, cooling, mechanical ventilation and lighting.

Planning and design principles

To respond to the local features of a subtropical climate housing incorporates the following features:

Site planning

- P1. Undertakes a site analysis as the first step to determine the sites opportunities and constraints.
- P2. Optimises solar aspect on the site, and integrates indoor with external living spaces.
- P3. Elevated housing, spaced apart, captures cooling summer breezes.
- P4. Retains (or plants) vegetation, in particular trees, for shade.

Materials

- P5. Generally uses insulated lightweight building materials with plenty of opening windows enabling quick release of heat during summer months, but retention of internal heat source during winter months.
- P6. Low thermal mass construction due to the low diurnal range. Where incorporating an element of thermal mass (masonry), ensure that it is appropriately ventilated during summer months to quickly release the stored heat.
- P7. Uses light coloured walls and roofs to reflect more solar radiation and reduce heat gain.
- P8. Minimises solid masonry fencing and high retaining walls as this blocks cooling breezes to the ground floors and yard spaces.
- P9. Incorporates insulation to roofs, ceilings and walls.

Floor plan and building principles

- P10. Designed with living space to the north east, north or north west as the best solar aspects. All west and east facing walls and windows should be shaded year round.
- P11. Designed with narrower floor plans to assist with cross ventilation, alternatively designed with openings to capture prevailing breezes.

- P12. Designed with higher volumes with higher level openable windows in living spaces to assist with stack and cross ventilation.
- P13. Reduced house profile and windows facing west. Long western elevation extensively shaded with deep eaves, window hoods or a covered verandah to act as a buffer to hot summer sun.
- P14. Maximises the indoor and outdoor relationship with screened and shaded areas and rain protected outdoor areas, such as large and covered verandahs accessed directly off living spaces.
- P15. Multiple outdoor living rooms to take advantage of the sunny side (for winter) and the shady side (for summer) of the house.
- P16. Covered clothes drying areas are included.
- P17. Incorporates ceiling fans.

Objectives

- O1. To ensure the dwelling is designed and sited to provide all habitable rooms with direct access to fresh air, to assist in promoting thermal comfort for occupants and to maximise sunlight and daylight access to living spaces and external living areas.
- O2. To encourage the use of passive solar and climate appropriate design.
- O3. To encourage natural ventilation in non-habitable rooms.
- O4. To reduce energy consumption by minimising the use of mechanical ventilation.

Controls

- C1. The dwelling is to be sited to encourage a balance of solar access (during winter months) and shading (during summer months) to primary windows and doors of living space and external living areas. This is to be demonstrated on a site analysis.
- C2. The plan layout, including the placement of openings, is to be designed to optimise access to prevailing breezes and to provide for cross-ventilation, demonstrated on a site analysis.

Living spaces and decks orientated north to take advantage of the northern aspect and views.

Generous sliding door width and high level louvres capture prevailing breezes and assist in stack ventilation.

Use of predominant lightweight materials suitable to the subtropical climate and generally have lower embodied energies.

Timber vertical screens and landscaping to the western elevation assist with shading and reduction of heat loads during winter months.

Generous rear deck provides transition between internal and external spaces as well as a refuge from the hot summer sun.

Strategic location of window and door openings to capture and channel prevailing breezes.

5000 Ltr water tank harvests and stores rainwater for reuse in the toilets, washing machines, gardens and pool.

Photovoltaic and solar hot water on roof.



Sample Passive Design - Illustrate and notate the principles of passive design as part of a site analysis.

4.3. Solar access and natural ventilation

It is important when designing buildings to consider **access to sunlight and natural ventilation as well** as the impact on the solar access of the adjoining properties. In some instances, overshadowing may be unavoidable however unreasonable overshadowing of neighbours as a result of poor design is not acceptable.

Planning and design principles

- P1. **Maximises sunlight access and natural ventilation whilst minimising potential sunlight access and overshadowing issues for adjoining properties.**
- P2. Small lot housing sites that are often constrained by narrow frontage, incorporate north facing courtyards, internal voids and double volume spaces combined with highlight windows to improve solar access and natural ventilation.

Objectives

- O1. To ensure the dwelling is sited and designed to maximise sunlight and daylight access and natural ventilation to living spaces and external living areas.
- O2. **To minimise the potential impacts on solar access and natural ventilation to adjoining properties.**

Controls

- C1. Two storey or greater development must prepare shadowing diagrams over the subject and adjoining sites for the summer solstice (21st December), winter solstice (21 June) at the times of 9am, 12pm and 3pm. Shadow cast by fences, roof overhangs and changes in level are to be considered and should be indicated on shadow diagrams submitted.
- C2. Private open space of the subject dwelling is to receive at least two hours sunlight between 9am and 3pm on June 21.
- C3. Windows to north-facing habitable rooms **or external living spaces** of the subject dwelling are to receive at least 3 hours of sunlight between 9am and 3pm on 21 June over a portion of their surface.
- C4. For neighbouring properties ensure:
 - i. Sunlight to at least 50% of the principle area of private open space of adjacent properties is not reduced to less than 2 hours between 9am and 3pm on June 21, and
 - ii. Windows to living areas must receive at least 3 hours of sunlight between 9am and 3pm on 21 June.
 - iii. Where existing overshadowing by buildings is greater than this, sunlight is not to be further reduced by more than 20%.
- C5. New dwelling design should minimise overshadowing on existing adjacent solar panels where other reasonable design alternatives are possible.

4.4. Building form

Building form combined with material and fenestration composition has the ability to significantly influence the resultant bulk, scale, mass and visual appearance of a building which can then influence streetscape character.

Planning and design principles

- P1. Bulk and mass of a building is broken up into a series of intersecting forms which relate to the site and internal configuration.
- P2. On sloping blocks the building form steps to take up the level change within the building envelope and the roof is designed as a series of planes with varying pitches to reduce the overall visual bulk.
- P3. Small lot housing sites, that are often constrained by narrow frontage, consider single room width layouts and small courtyard areas to improve internal amenity.
- P4. Large expanses of unarticulated wall planes are minimised. Articulation can be achieved by:
 - i. including architectural elements and detailing such as entrance portico's, window hoods.
 - ii. by stepping, recessing, cantilevering or projecting building form elements and roofs including verandas thereby avoiding long unbroken elevations;
 - iii. using a series of roof forms rather than one single roof form;
 - iv. using a range of building materials and cladding types, colour and textures to create architectural interest.

Note:

Building articulation is how each building element, such as three dimensional form, fenestration, structure or floor plate configuration is architecturally expressed. This can be done through building form including projections, cantilevers and recesses, the use of colour, change of material or texture. The idea is to make these elements read differently creating elevation interest while still retaining a coherent pleasing composition overall.

Objectives

- O1. To minimise the visual impact and bulk of development when viewed from adjoining properties, the street, waterways, and areas for public recreation purposes.

Controls

- C1. Building siting, height, scale, and roof form must relate to the **surrounding development**, topography and the existing site conditions.
- C2. Walls in excess of 15m in length and/or 4m in height must be articulated, landscaped, or otherwise treated in order to provide visual relief. Planning and design principle 4 above identifies various articulation techniques.
- C3. **Buildings on corner sites are to be designed and articulated to address both streets frontages.**

4.5. Visual and acoustic privacy

Visual privacy allows residents to carry out private activities within all rooms and private open spaces without compromising the functioning of internal and external spaces. Visual privacy is determined by the nature of adjacent developments, site configuration, topography, the scale of the development, and the layout of individual dwellings.

Acoustic privacy relates to the potential transference of sound between individual dwellings, and between external and internal spaces. Designing for acoustic privacy considers the location and separation of buildings, the location of internal and external living areas and above ground areas such as terraces.

The acoustic privacy may also be impacted by the proximity of the building to major external noise sources such as busy roads and aircraft.

Setbacks, separation between dwellings, and the appropriate location of external living areas, provide the primary method of ensuring acoustic privacy.

Planning and design principles

Dwelling design incorporates the following:

- P1. Identifies potential visual and acoustic privacy impacts through a site analysis. This includes identifying windows and external living spaces of adjoining dwellings/buildings and then designing to avoid direct line of sight into proposed windows, internal and external living spaces.
- P2. Locates habitable rooms and windows to the front and rear elevations where privacy and outlook are more easily achieved.
- P3. Terraces and balconies (especially if elevated) are designed to have a generous building separation and screens where required to avoid loss of amenity and visual privacy and minimise noise transfer.
- P4. Small lot housing includes internal voids and double volume spaces combined with highlight windows to maximise privacy and minimise overlooking impacts.

Objectives

01. To enable visual privacy for internal and external spaces whilst allowing for a level of surveillance over the street.
02. To facilitate outlook and views from principle rooms in dwellings and private open spaces without compromising visual privacy.
03. To minimise overlooking of neighbouring dwellings and external living spaces.
04. To encourage a high level of acoustic privacy through minimising exposure to noise sources, such as traffic and aircraft noise, and minimising the impacts of noise generating uses such as air conditioners, pumps, and other mechanical equipment on the dwelling and the adjoining dwellings.

Note:

Design Control 3.1 - Setbacks also contains provisions relating to visual and acoustic privacy and should be read in conjunction with these controls.

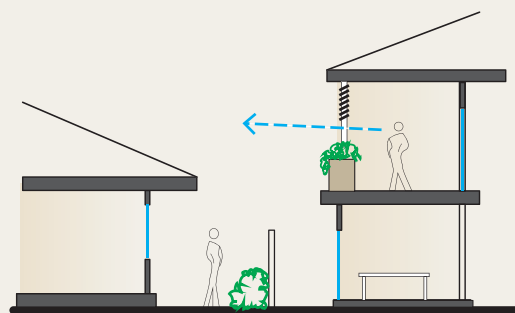
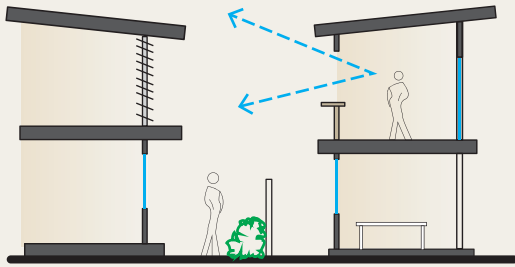

Use screening devices including planter boxes and screens to protect privacy while also providing sunlight access and an outlook.

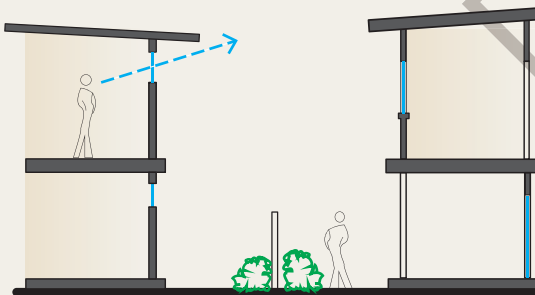

Where other measures are not able to be used, provide high level window sill heights to address privacy and overlooking concerns.

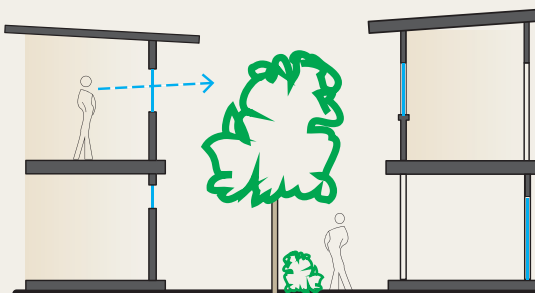

Use landscaping to assist with visual screening and creating private outlooks.

Controls

- C1. Terraces, balconies, living room and kitchen windows are to avoid a direct view into neighbouring dwellings or neighbouring private open space.
- C2. Decks, verandahs, terraces, balconies and other external living areas within 4 metres from a side or rear boundary may require a privacy screen unless it can be demonstrated that there will be negligible overlooking and/or privacy impacts, as demonstrated on a site analysis.
- C3. Side windows are to be offset by distances sufficient to avoid visual connection between windows of the subject dwelling and those of the neighbouring dwelling. Location of existing **adjoining** property windows are to be documented on a site analysis.
- C4. The location of external living areas, swimming pools, spas and other potential sources of noise transfer shall consider the proximity to and potential impacts on habitable rooms of adjoining allotments.
- C5. The noise of an air conditioner, pump, or other mechanical equipment must not exceed the background noise level by more than 5dB(A) when measured in or on any premises in the vicinity of the item. These items must be positioned away from neighbouring dwellings, particularly bedrooms, habitable rooms and external living spaces. These items may require a sound proofed enclosure.
- C6. For new dwellings located on arterial roads, designated roads, classified roads **or where exposed to aircraft noise**, consideration is to be given to the need for acoustic treatment to mitigate noise impacts.

4.6. Roofs, dormers, attics and skylights

The roof is an important architectural element for the overall composition and expression of a building. The shape and form of a roof and its associated elements should respond to various viewpoints within the local context, such as the roofscape observed from higher locations and the silhouette viewed from the street. In some areas the roof forms part of a distant view and sits within a larger skyline vista.

Attics can provide additional floor space whilst helping to reduce the overall height of buildings. An attic is a space that is contained within a pitched roof of a building. Attic rooms require either skylights or dormer windows for light and air.

Planning and design principles

Roof design is an integral part of the building design through:

- P1. Articulating the roof with a series of roof planes and pitches rather than a single homogenous roof line;
- P2. Eaves, or other shading devices, protect the dwelling from direct solar penetration;
- P3. The roof form, slope, material and colour is compatible with adjacent buildings;
- P4. The roof height is in proportion to the wall height of the building;

Objectives

01. To contribute to the design and performance of buildings.
02. To integrate the design of the roof into the overall elevation and building composition.
03. To contribute to a consistent and attractive streetscape.
04. To provide shading and weather protection.
05. To ensure that where attics are provided, the bulk and scale of the development is compatible with the surrounding residential context.

Controls

- C1. Roofs **should** incorporate at least 600mm deep eaves for shading of facades, particularly on west facing elevations. **Alternate sunshading measures including external louvres, screens and window hoods are also acceptable solutions.**
- C2. Roof materials and skylights should not cause excessive glare and reflection and roof colour should be consistent with the existing locality.
- C3. Attic spaces cannot be more than 50% of the floor below with the majority of the volume of an attic to be contained within the roof space.
- C4. Minimum ceiling heights of 2.7 metre are encouraged for habitable rooms. For habitable rooms with a raking ceiling it is preferable to have at least 30% of the ceiling with a minimum 2.7 metre height.

4.7. Garages, driveways and car parking

The controls relating to location and design of car access and parking areas are to ensure that the site and the streetscape are not dominated by car related uses and to ensure that access and car parking does not compromise the privacy and amenity of the site or adjoining dwellings.

Carparking should be convenient, designed to meet the needs of residents and integrated with the overall site design to minimise visual and environmental impacts.

Planning and design principles

Note:

Design Control 3.1 - Setbacks also contains provisions and diagrams relating to corner blocks and should be read in conjunction with these controls.

Note:

Design Criteria 3.1 - Setbacks of this Code also contains provisions relating to setbacks of carports and garages which should be read in conjunction with these controls.

Design Control 3.2 - Building heights also contains provisions relating to garages and carports and should be read in conjunction with these controls.

- P1. Separation between vehicular and pedestrian access points ensures good visibility between the two.
- P2. Site planning enables suitable car access and parking without dominating the streetscape.
- P3. In dual occupancy development co-joining double garages is to be avoided as this results in a long garage elevation to the street. Garages are separated with landscaping or screening walls to breakdown their visual impact.

Objectives

- O1. To facilitate on site car access, parking and manoeuvring areas.
- O2. Minimise driveways and hardstand areas to maximise the area for landscaping and deep soil zones and to reduce the visual impact of driveways and hard surfaces from the street.
- O3. To minimise the physical and visual dominance of vehicles and garage doors on sites.
- O4. To minimise footpath and street reserve crossings.

Controls

- C1. Carparking and driveways are to be in accordance with Section A2 of the Tweed Shire Development Control Plan and Council's Driveway Design Specification.
- C2. Carports and garages visible from the public street are to:
 - i. Be compatible with the building design, including roofs; and
 - ii. Be treated with materials and colours and windows which ensure the garage or carport is less visibly intrusive to the streetscape.
- C3. Car parking entries are encouraged to be located off secondary streets and laneways where these occur.
- C4. Vehicular movement, driveways and parking areas are to be designed to minimise dimensions, to reduce hard surfaces on the lot, and increase the area available for landscaping. Permeable driveway surface treatments are encouraged.

Driveway configurations are to maintain appropriate sight lines and safe visibility in accordance with Council's Driveway Design Specification.

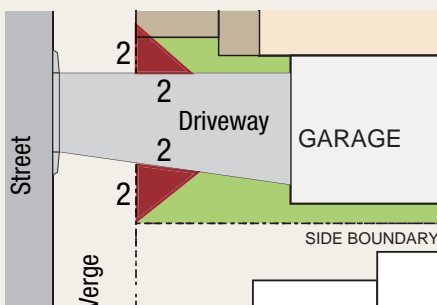

Red splay shaded areas denote visually clear zone.

- C5. Allotments less than 450 sqm and with a street frontage less than 10m are encouraged to provide rear laneway access to garages. Garages to the primary street frontage will only be considered where either a single garage is provided or a two storey building form with projecting first floor balcony mitigates the visual impact of the double garage.
- C6. Driveways may be located adjacent to the side boundaries only where front fences above 600mm have a 60% openness ratio for the first 2 metres along the boundary adjacent to the driveway to achieve pedestrian and traffic sight lines as set out in AS2890.
- C7. Where vehicles would otherwise have to reverse more than 50 metres, where the site is steep, fronts a busy road or is in a high pedestrian area, driveways should be designed so that the vehicles can enter and leave the site in a forward direction.
- C8. In stacked dual occupancy configurations, avoid double garages at the termination of the access handle for the rear allotment to minimise visual impact.

Garages

- C9. Garage doors to a street frontage cannot be more than 50% of the street frontage or 6 metres, whichever is the lesser.
- C10. Garage doors along a laneway may take up greater than 50% of the frontage. Providing a pedestrian access way directly from the laneway to the lot is **provided**.
- C11. Where a garage entry faces the side boundary, articulation, windows and landscaping are to be provided to the street elevation of the garage.

Carports

- C12. Carports cannot be wider than two car spaces width or 6 metres.
- C13. A maximum of two carport spaces can be stacked down the site.
- C14. Carports must not necessitate an extra driveway additional to the driveway for a garage or other parking structure.
- C15. The carport must have at least two sides open and cannot be fitted with a door, fence or gate.
- C16. Carports cannot have rooms within the roof.

Basement carparking

- C17. Basement carparking cannot extend more than 1 metre above natural ground level where it faces a public street or public space or 1.5 metre above natural ground level to the side and the rear of the lot where it does not face a public street or public space.
- C18. A ramp entering off a public street must start behind the boundary. Ramps cannot be located on public land and the width of ramps is to be minimized.
- C19. Basement car parking is not to extend outside the building footprint.

5. Operational requirements

5.1. Waste management

The minimisation and management of waste from development can contribute to the visual and physical amenity of the building as well as limiting potentially harmful impacts on the environment. Minimising waste is relevant to all stages of the building's life cycle, from construction to demolition. It also includes the way in which waste is stored and collected.

Planning and design principles

- P1. Recycle and reuse demolished materials, where possible;
- P2. Specify building materials that can be reused and recycled at the end of their life;
- P3. Integrate waste management during the design stage by:
 - i. Reducing waste by utilising the standard product/component sizes of the materials to be used,
 - ii. Incorporating durability, adaptability and ease of future services upgrades;
- P4. Locate storage areas for rubbish bins away from the front of the building so as to minimise negative impacts on the streetscape. Provide every dwelling with a waste cupboard or temporary storage area of sufficient size to hold a single day's waste and to enable source separation; and
- P5. Incorporate on-site composting.

Note:

DCP Section A15 provides additional controls related to waste minimisation and management.

Objectives

- 01. To plan for the types, amount and disposal of waste to be generated during demolition, excavation and construction of the development.
- 02. To encourage waste minimisation, including source separation, reuse and recycling.
- 03. To ensure efficient storage and collection of waste and quality design of facilities.

Controls

- C1. Any application for development that involves the demolition of existing structures is to provide a Demolition Work Plan in accordance with the provisions of AS2601 and Councils work plan requirements.
- C2. Excavation that will result in waste material having to be transported off-site must be minimised through the use of site responsive building design. Where practical, excavated material should be reused on-site.

6. Ancillary development

Ancillary development comprises minor building works and may include, but is not limited to, carports, swimming pools, balconies, decks, shade structures and the like, associated with a dwelling. Whilst minor in nature and scale, these structures can impact on the amenity of neighbours and the streetscape when poorly located or designed.

6.1. Fences and walls

Fences and walls include all built vertical landscaping elements designed to define boundaries between one space and the next or to accommodate a change in level.

The design of fences and walls has an impact on the real and perceived safety and security of residents as well as on the amenity of the public domain and the streetscape character. The visual impact, scale and design of fences all need to be carefully considered.

Fences play an integral part in the development and contribution to the streetscape. Ideally front, and side fences to corner allotments, should integrate with the street allowing residents to use the 'street spaces' while retaining 'private spaces'. High front fences create 'walled streets' which turn dwellings in on themselves rather than contributing to the liveliness of the street, generally result in less pedestrian activity and are more prone to graffiti and vandalism. However, in some locations, such as on main roads, higher front fences provide much needed privacy and buffer to noise intrusion.

Planning and design principles

Front and side fences, especially to corner allotments, contribute to amenity of the streetscape through:

- P1. Consideration as an integral part of the house and site design;
- P2. Avoiding long expanses of solid masonry, timber paling or colourbond blank walls;
- P3. Using a mix of materials which integrate with the design and materials of the dwelling;
- P4. Incorporating transparent elements within the fence design to enable passive surveillance of the street, allow breezes to flow through and encourage interaction with neighbours;
- P5. Integrating landscaping which includes a variety of plant types, such as trees and lower shrubs, as appropriate; and
- P6. Providing elements of visual interest and shading from trees to contribute to pedestrian activity and walking amenity.

Note: A large percentage of ancillary development may now occur as exempt development under the provisions of the State Environmental Planning Policy (Exempt and Complying Development), the Code SEPP, and therefore do not require a development application (DA).

Applicants are advised to also refer to the Code SEPP for exempt or complying development provisions relating to types of ancillary development.

Objectives

01. To define the boundaries between public and private land and between neighbouring properties.
02. To integrate with the streetscape appearance.
03. To enhance the usability of private open space.
04. To offer acoustic and visual privacy on busy roads.

Controls

General

- C1. Fences and walls are not to impede the natural flow of stormwater runoff.
- C2. If located in a bushfire prone area fences and walls are to comply with AS3959 and Planning for Bush Fire Protection 2006, as amended from time to time.
- C3. Fencing is not to obstruct water meter reading access.

Front and return

- C4. Front and return fences are to reflect the design character of the dwelling and be compatible with other fences and walls within the streetscape.
- C5. Return fences (the side fence between the front boundary and front elevation of the house) are to be the same height and design as front fences.
- C6. Front and return fences to a primary or secondary street frontage can be up to maximum height of 1.5 metres high with a maximum solid fence height of 600mm. Above the solid wall the fence is to have a minimum openness ratio of 60%. These height may be varied where topography necessitates a retaining wall as demonstrated on a site analysis.
- C7. Front or return fences must not be timber paling or colourbond, except were integrated into a design theme that is consistent with the character of the dwelling and streetscape and incorporates appropriate articulation to allow for landscaping.
- C8. Front fences are not to obscure a 2.0m x 2.0m splay when adjacent to a driveway.
- C9. Front and return fences may be solid up to 1.8 metre if:
 - i. Located on an arterial road or opposite an intersection where head lights shine into a dwelling; or
 - ii. Where a swimming pool is located forward of the front building line; or

- iii. Where the allotment is oriented to the north, providing the most suitable location for private open space and external living areas; and
 - Are justified by a site analysis;
 - Include articulation and landscaping to the street(s);
 - Must not be a solid unbroken wall and the solid component cannot be more than 50% of the street frontage; and
 - Must not be colourbond or timber paling.

Side and rear

- C10. Side fences are measured from behind the required building line to the rear boundary. The maximum side or rear fence height is 2.0 metres.
- C11. May include timber paling, metal or Colourbond material. If metal must be of low reflective material.
- C12. Chain wire fences, **except to tennis courts**, are not to exceed 1.2 metres in height.
- C13. On corner allotments, fence and wall treatments on the secondary street frontage are to be of equal design quality and material as the primary street frontage for the length of the building.

Note:

6.4 Tennis Courts also contains fencing controls

Fences and walls for Greenbank Island

- C14. Approval is to be obtained from Council prior to the erection of any fencing on Greenbank Island.
- C15. Fencing behind the six (6) metre building line shall not exceed 2000mm in height.
- C16. The fencing is to be constructed of brick, stone, masonry block or such other material as is approved by Council.

INDICATIVE FENCE CONTROL DIAGRAMS

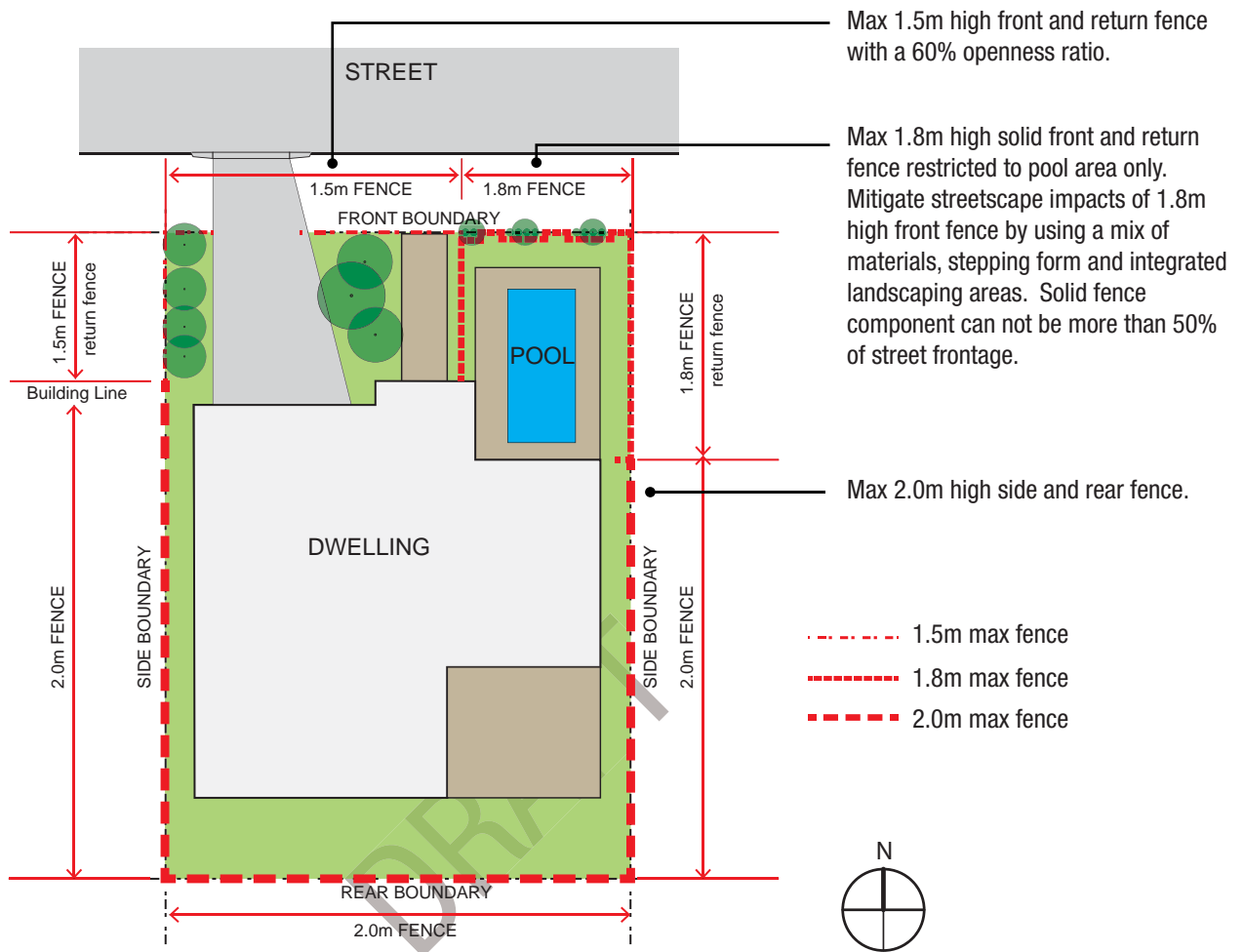

Indicative front fence design with pool in the front yard. A 1.8m high fence in the front yard is permitted for the extent of the pool only.

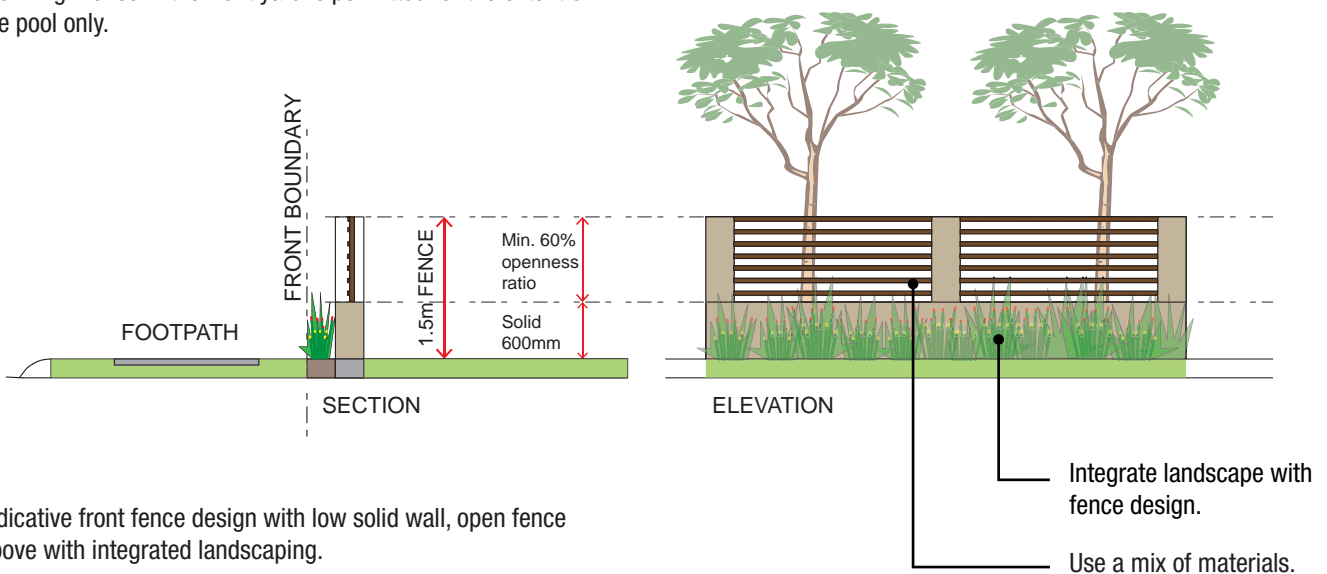

Indicative front fence design with low solid wall, open fence above with integrated landscaping.

6.2. Outbuildings

Outbuildings are ancillary structures to the main dwelling. They are small scale detached buildings that are visually consistent with the design of the dwelling. Examples of outbuildings include boatsheds, workshops, storage sheds, garden sheds, greenhouses, cabanas and gazebos.

Objectives

Note:

Outbuildings are defined in the State Environmental Planning Policy (Exempt and Complying Development) Codes SEPP, and may be permitted under the Code SEPP exempt or complying development provisions. Applicants are advised to also refer to the Code SEPP for exempt or complying development provisions for outbuildings.

01. To provide for uses complementary to a dwelling house.
02. To ensure outbuildings are of an appropriate scale and compatible in design and materials with the existing dwelling house.
03. To maintain the existing or reinforce the desired future character and streetscape of the area and preserve the amenity of the existing dwelling house and any neighbouring properties.
04. To ensure that deep soil zones and significant trees or vegetation are not adversely impacted.
05. To make allowance for contemporary living designs that comprise free standing outbuildings for residential uses such as; studios, parent/kids retreat, study/home office, bedroom, living / entertainment space, but not including a dwelling.

For the purposes of this criteria, 'outbuildings' will have the same meaning as the State Environmental Planning Policy Housing Code.

Design Control 3.1 - Setbacks also contains provisions relating to outbuildings and should be read in conjunction with these controls.

Controls

- C1. Outbuildings are to be single storey, except when located on either rural or agricultural land.
- C2. Deep soil areas cannot be used for the siting of an outbuilding.
- C3. An outbuilding may include a toilet, wash basin and/or shower but may not be used as a dwelling and may not contain a kitchen.
- C4. The total area for outbuildings on a site (including carport) is:
 - i. 50m² for lots up to 450m²;
 - ii. 60m² for lots greater than 450m² and up to 900m²;
 - iii. 100m² for lots greater than 900m²; and
 - iv. These size restrictions do not apply on non-urban zoned land or rural living (large lot residential) land.
- C5. Outbuildings are to have a maximum overall building height of 3.5 metres for a flat roof and 4.8 metres for a pitched roof. This control does not apply to land with either a rural living (large lot residential) or agricultural zoning.
- C6. Outbuildings must be located a minimum of 1 metre behind the front building alignment.
- C7. The design and materials are to be compatible with those of the dwelling house. Reflective and high glare surface finishes are to be avoided.

Note:

Design Control 3.1 - Setbacks also contains provisions relating to swimming pools and should be read in conjunction with these controls.

Design Control 4.3 - Visual and acoustic privacy also contains provisions relating to swimming pools and should be read in conjunction with these controls.

Swimming pool fences must comply with the relevant requirements for pool fences set out in the Swimming Pool Act 1992 (or as updated) and with Australian Standards (such as Australian Standard 1926 (or as updated). Compliance with the Australian Standard will generally mean that a 1200mm high fence, or where the fence is located on a property boundary a 1800mm fence, with self-closing, self-latching gates will need to be provided.

6.3. Swimming pools and spas

Swimming pools and spas enhance the amenity and livability of dwellings. However, care must be taken to ensure a high level of safety for children and to ensure they do not detract from the amenity of neighbours. It is important that swimming pools and pool fencing are not only built in accordance the Tweed Shire Council planning controls, but also with the relevant NSW Government Acts and Regulations and with relevant Australian Standards.

Planning and design principles

Safety and the protection of the privacy and amenity of the pool owners and adjoining residents are important considerations. Pool design incorporates the following:

- P1. Safety for occupants, visitors and neighbours.
- P2. Considers the pool location and associated deck areas in relation to habitable rooms of adjoining properties;
- P3. Encloses and locates the pool filter away from property boundaries and habitable rooms;
- P4. Pools are located so that they will not damage mature trees, either on the subject site or those within neighbouring properties.

Objectives

01. To ensure maximum safety of pool areas.
02. To ensure maximum child safety.
03. To minimise the impact of swimming pools and spas on neighbours.

Controls

- C1. The outer edge of the pool concourse or coping shall set back a minimum of 1 metre from the side or rear boundaries.
- C2. Swimming pools and spas must be surrounded with a child resistant barrier in accordance with the provisions of the Swimming Pools Act and the requirements of Australia Standard 1926.
- C3. Swimming pools and spas are to have a suitable means for drainage and disposal of overflow water.
- C4. Filters and pumps are to be enclosed and located in a position so as not to cause a noise nuisance to adjoining properties and habitable rooms.
- C5. Adequate deep soil zone is to be retained.

Note:

The wall of a residential building may form part of the child resistant barrier so long as the wall contains no opening door, window or other opening through which access may at any time be gained to the swimming pool.

- C6. Pools may be located between the **front building line** and the street where it can be demonstrated through a site analysis plan that:
- i. This is the best solar orientation for the pool, and associated external living areas;
 - ii. That the impact on habitable rooms of the adjoining and opposite properties is minimised; and
 - iii. Fencing to the street is not timber paling or colourbond and incorporates a mix of materials, articulation and landscaping.

6.4. Tennis courts

Tennis courts are to be designed and sited to ensure that the potential impact on neighbours is minimised. Lighting where provided is to be designed to ensure that upward and outward light spillage is minimised or eliminated.

Objectives

- O1. To ensure tennis courts are designed and located to minimise excessive noise, loss of privacy or light spill of artificial lighting impacts on neighbouring properties.
- O2. To ensure that tennis courts do not adversely affect the amenity of their locality by their visual impact.
- O3. To retain, where possible, existing trees.

Controls

- C1. Tennis court lighting is to comply with the provisions of Australian Standard 2560.1 (or as updated) and is to be designed and shielded to eliminate upward and minimise outward spillage of light.
- C2. Tennis courts shall be designed to adequately accommodate drainage requirements within the site.
- C3. Tennis courts shall be located behind the building line of any primary frontage except where on rural land or non-urban land.
- C4. Tennis courts cannot be located within the deep soil zones.
- C5. For tennis courts or other similar areas, chain wire fences **are to be of a dark colour and designed to reduce visual impact**. Tennis court fencing is to be screened with landscaping.
- C6. Solid fences enclosing these facilities shall not be permitted over 3.6 metres, shall be offset from the side boundary by a minimum of 600m and offset any front boundary by 1 metre.

DRAFT

7. Appendix

7.1. Development application submission requirements

Council's submission requirements for all residential and tourist development types lodged as a development application are listed within the "Development Application Guide". Development Applications are to be lodged consistent with these requirements.

Material to be submitted by the applicant at DA stage	Part A Dwelling Houses, Dual Occupancy, Secondary Dwellings	Part B Multi-Dwelling Housing,	Part C Residential Flat Buildings, Shop top Housing
Pre DA Meeting		✓	✓
Concept Plan - Scale of 1:100 or 1:200			
Submission of a concept plan showing:			
Sufficient information for the Development Assessment Panel (DAP) to provide meaningful assessment and feedback		✓	✓
Completed DAP details form		✓	✓
Development Application			
Site Plan 1:100 or 1:200			
Consistent with the requirements within the document ' <i>Development Application Guide</i> '. Site plan to include but not be limited to: <ul style="list-style-type: none"> Title block, scale, north point Legal description Property boundaries with dimensions and bearings Key topographic and landscape features Contours and levels Service and easement locations Overall proposed works layout including existing and proposed building locations including fences and structures, points of access and egress 	✓	✓	✓
Site Analysis			
Consistent with the requirements of Preliminary Information Part 4 - Context and Site Analysis and the site analysis checklist - Appendix 7.2 . The site analysis is to be graphically illustrated, notated and tailored to suit the site, context and complexity of development. Site analysis to include but not be limited to: <ul style="list-style-type: none"> Overlay of proposed with above site plan demonstrating relationship of design to site and contextual conditions Overlay key climatic and sun path diagrams Overlay key view lines Details of adjoining buildings Clearly illustrate and notate areas of non-compliance 	✓	✓	✓

Material to be submitted by the applicant at DA stage	Part A Dwelling Houses, Dual Occupancy, Secondary Dwellings	Part B Multi-Dwelling Housing,	Part C Residential Flat Buildings, Shop top Housing
Site Analysis (Cont.)			
Streetscape elevations			✓
Photographs for at least 50 metres in both directions, or three adjacent properties in both directions, whichever is the lesser of represents a more complete contextual reference. (For site(s) with multiple street addresses, photographs are to be prepared for each separate address).			✓
Site works plan (this may form part of the site plan):			
The location of cut and fill earthworks with existing and finished levels	✓	✓	✓
Location of top and bottom cuttings, fill embankments and associated batter and/or retaining walls and proximity to allotment boundaries	✓	✓	✓
Pre and post development ground levels on the allotment. Where cut and fill is in excess of 1 metre in height, or where earthworks are within 1 metre of an allotment boundary, the levels shall extend at least 2 metres (horizontally) into adjoining land (so that the impact on adjoining land may be assessed)	✓	✓	✓
Details of associated retaining walls, safety railings, batter treatments, drainage and landscaping.	✓	✓	✓
Location and depth of service trenches in areas affected by cut and fill	✓	✓	✓
Erosion and sediment control plan	✓	✓	✓
Water management plans			✓
<p><i>Council may require an approved geotechnical and structural engineers report for earthworks in:</i></p> <ul style="list-style-type: none"> <i>Areas where there is a risk of landslip and excessively steep sites (>16 degrees)</i> <i>Lots that are supported by, or adjoin higher lots that are supported by existing retaining walls or cut/fill batters that exceed 1 metre in height and the new work may affect the integrity of the wall or batter</i> <i>Lots where proposed earthworks batter slope exceeds 1:2 (V:H)</i> <i>Proposals where the height of cut or fill will exceed 1 metre in height</i> <p><i>The geotechnical and structural engineers report shall include but not be limited to:</i></p> <ul style="list-style-type: none"> <i>An assessment of the stability of the proposal (for both the subject lot and adjoining land)</i> <i>Recommended design criteria for earthworks, retaining walls and associated drainage</i> <p><i>Council will assess the suitability of any cut or fill within these areas dependent upon the recommendations contained in the above reports.</i></p>			

Material to be submitted by the applicant at DA stage	Part A Dwelling Houses, Dual Occupancy, Secondary Dwellings	Part B Multi-Dwelling Housing,	Part C Residential Flat Buildings, Shop top Housing
Proposed development - scale 1:100 or 1:200			
Floor plans showing:			
All floor and roof plans with layouts and dimensions	✓	✓	✓
Finished floor levels and adjoining external levels	✓	✓	✓
Parking, vehicular and pedestrian access / entries	✓	✓	✓
Fenestration, balcony and outdoor areas	✓	✓	✓
Schedule of net and gross areas, site coverage and landscape areas	✓	✓	✓
Elevations showing:			
Height and key datum lines	✓	✓	✓
Building dimensions and articulation	✓	✓	✓
Facade composition, materials and colours	✓	✓	✓
Roof design	✓	✓	✓
Building entries (pedestrian, vehicular and service)	✓	✓	✓
Sections showing:			
Whole of site sections (boundary to boundary) accurately representing the grade of the land at different intervals and proposed finished ground line / levels.	✓	✓	✓
Existing and proposed ground level lines and maximum building height line	✓	✓	✓
Proposed building heights and adjoining buildings and structures	✓	✓	✓
Finished floor and Ceiling heights	✓	✓	✓
Location of and height of neighbouring buildings	✓	✓	✓
The relationship of the proposal to the ground plane, the street and open spaces	✓	✓	✓
the location and treatment of car parking	✓	✓	✓
indicative ground plane treatment and deep soil zones, locations and planting scheme		✓	✓
Shadow diagrams for any 2 storey development or greater showing:			
Illustrate footprint of the proposed building/works over the site and all adjoining buildings	✓	✓	✓
Shadow diagrams need to show solar access to the site and adjacent properties at summer solstice (December 21) and winter solstice (June 21) at 9:00am, 12:00 midday, 3:00pm.	✓	✓	✓
Shadows across key elevations (as required)	✓	✓	✓
Shadows cast by approved and/or existing development	✓	✓	✓

Material to be submitted by the applicant at DA stage	Part A Dwelling Houses, Dual Occupancy, Secondary Dwellings	Part B Multi-Dwelling Housing,	Part C Residential Flat Buildings, Shop top Housing
Shadows cast over existing solar panels to adjacent dwellings	✓	✓	✓
Models and Visualisations			
Submission of a series of photomontages visually depicting the proposed building within its context as required			✓
Use of 3D models to illustrate compliance with objectives			✓
Submission of a physical and/or digital model as required	✓	✓	✓
Landscape plans accurately showing:	Scale 1:100 or 1:200 for Dual occupancy		Scale 1:100 or 1:200
Building footprint of the proposal	✓	✓	✓
Any ramps, stairs and retaining wall levels	✓	✓	✓
Fencing, security and site entry/access points	✓	✓	✓
Built elements, such as pergolas, walls, planters, water features	✓	✓	✓
Trees to remain and proposed trees/planting scheme including species and size	✓	✓	✓
Trees to be removed shown dotted	✓	✓	✓
Open space and deep soil area calculations and locations	✓	✓	✓
Planting list including species, numbers and locations.		✓	✓
Stormwater management plan as required	✓	✓	✓
Submission of a Statement of Environmental Effects			

7.2. Site analysis checklist

The site analysis is comprised of graphical and written information which should indicate the following range of considerations, where appropriate, and address the likely impacts of the proposed development. **The level of assessment detail will be dependent on the nature, type and scale and potential amenity impacts of the proposed development.** The development application should demonstrate how the development proposal has responded to the opportunities and constraints of the site. The site analysis is to include details, as relevant, of the following:

Site and drawing description:

- Location and clearly defined site boundaries, bearings, legal description and dimensions
- North point
- The scale and date of the plans and drawings

Site details:

- Topographic elements including contours and levels (0.5m intervals)
- Driveway and cross over locations
- Service locations (water, sewer, electrical, communications)
- Easements
- Setback overlay
- The geotechnical characteristics of the subsurface condition / soil type
- Drainage and overland flow paths
- Any acid sulfate soils, landfill or contamination affectation and, where affected, proposed remediation strategy and statement from a recognised expert that the site can be remediated

Site climatic details:

- The orientation of the site, solar path (summer, winter)
- Direction of prevailing winds and weather patterns
- Identified significant heat load directions
- Identified significant shading influences (topography, fences, houses, trees)

Site context:

- Understand the form and character of adjacent and opposite buildings in the streetscape and adjacent sites, architectural character, front fencing and garden styles
- The location height and use of adjacent and opposite buildings
- The location and distance to adjoining dwellings and their windows, doors, main living spaces, external living areas, pools, solar panels, retaining walls and the like
- The location, height and materials of fences and/or walls built to the site boundary
- Any difference in levels between the site and adjacent and opposite dwellings in plan and sections

- Views to and from the site locally and regionally
- The species, location, height and canopy dimensions of any existing vegetation on the site, or within eight metres of the site, and identified as to be removed or retained
- Any heritage item or conservation area applying to or nearby to the site
- Any environmental attributes such as koala habitat, fauna corridors, bushfire hazards, fire source features, flooding, wetlands, endangered species or the like applying to, or nearby, the site
- Sources of noise nuisance such as flight paths, road noise or other noise pollution sources
- Any key natural features of the site and its surrounds such as rock outcrops, cliffs, embankments, foreshores or the like
- Direction and distance to local facilities, local shops, schools, public transport, recreation, open space and community opportunities for development within Parts B and C

Design response to site analysis in plan and section:

- Indicative footprint of the proposal over base site analysis information
- Demonstrate how internal living spaces relate to aspect and outdoor spaces
- Demonstrated cross ventilation and natural sunlight access
- Show the location of vehicular and pedestrian access points
- Nomination of where the proposal may overshadow or overlook or be overshadowed or overlooked by the adjoining dwellings their windows, doors, private open space, pools, solar panels, retaining walls and the like
- Nomination of the best location for landscaping, deep soil zones and outdoor living spaces
- Clearly identify areas where the site analysis indicates a suitable alternative solution to the controls

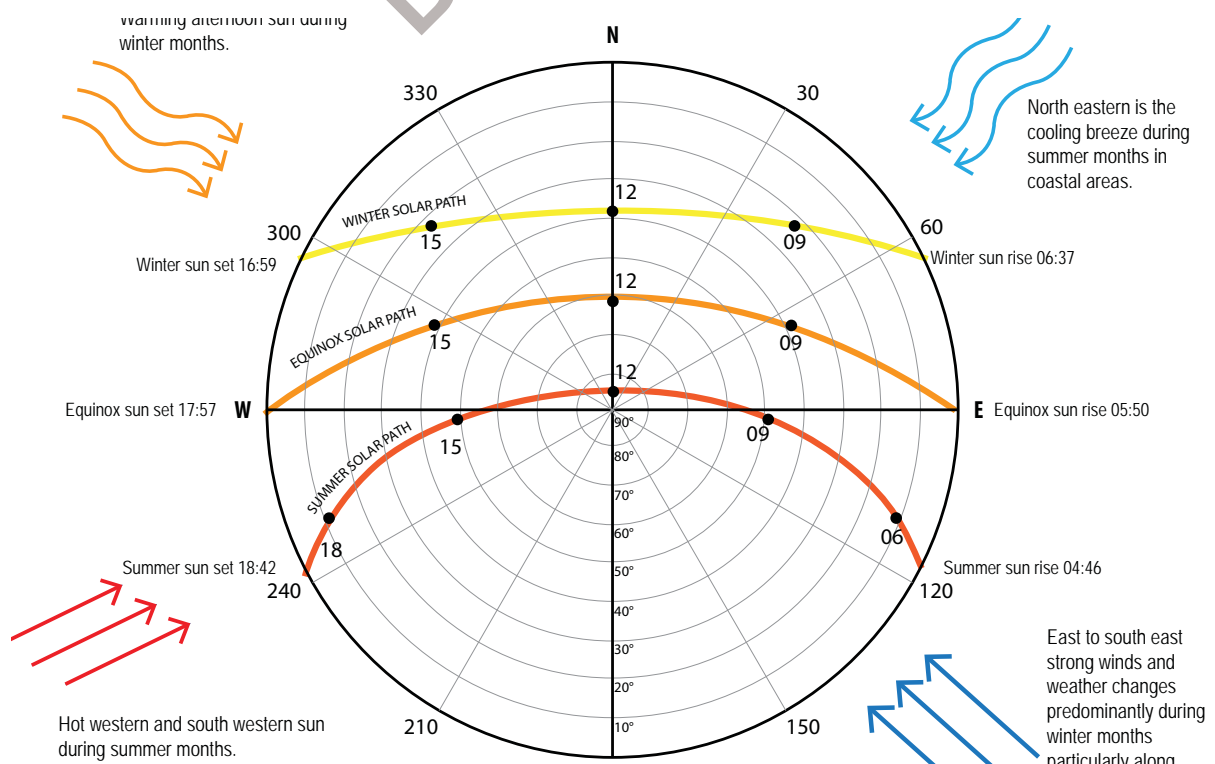

Tweed Solar Path Diagram - Solar path and prevalent climatic influences for the Tweed.

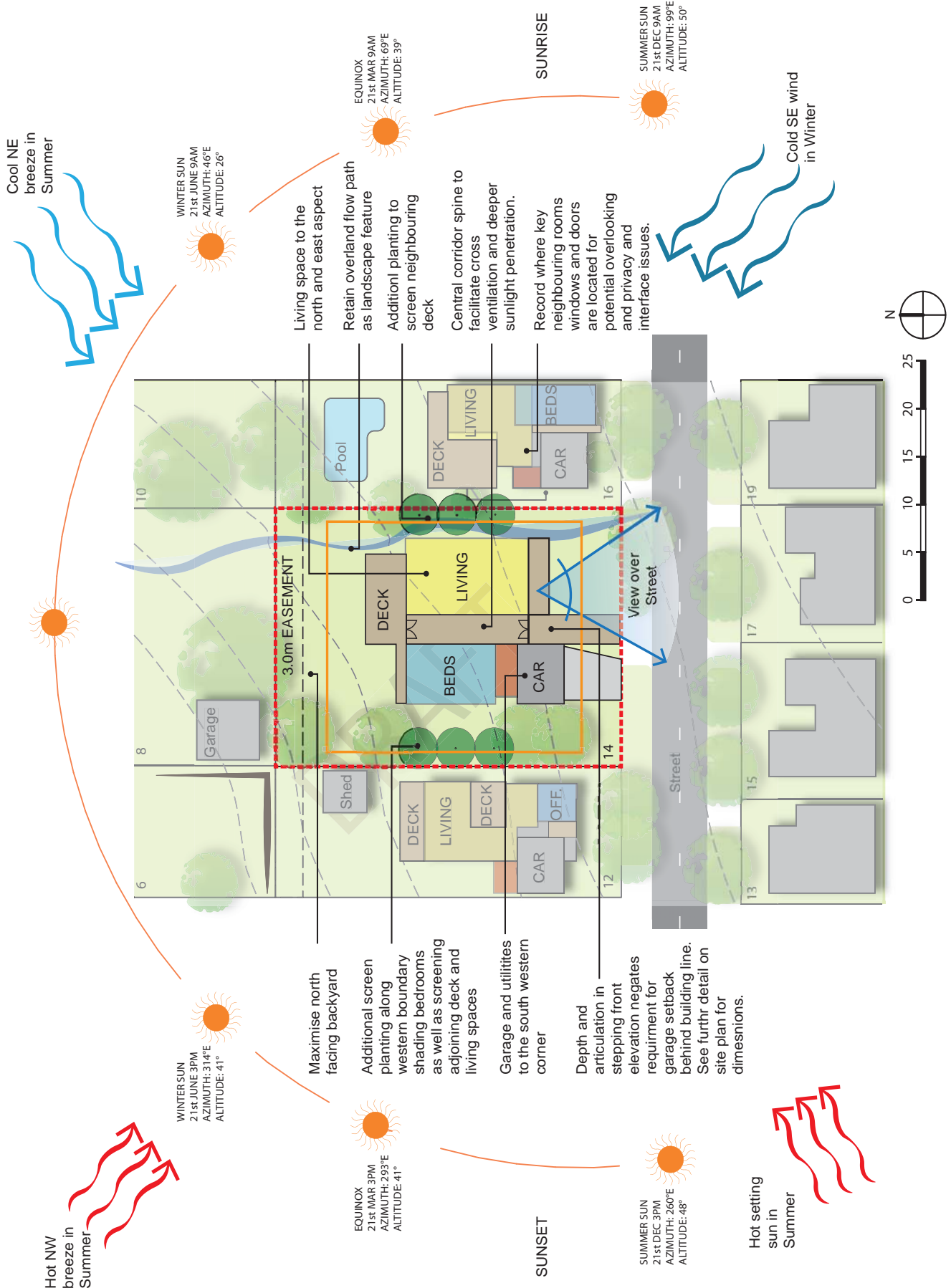

SITE ANALYSIS DESIGN RESPONSE - This sample site plan shows how the house siting, selection and design responds to the site analysis.



Customer Service | 1300 292 872 | (02) 6670 2400

tsc@tweed.nsw.gov.au

www.tweed.nsw.gov.au

Fax (02) 6670 2429

PO Box 816

Murwillumbah NSW 2484